

NASW 4066

553880

WORKSHOP ON

Analysis of Returned Comet Nucleus Samples

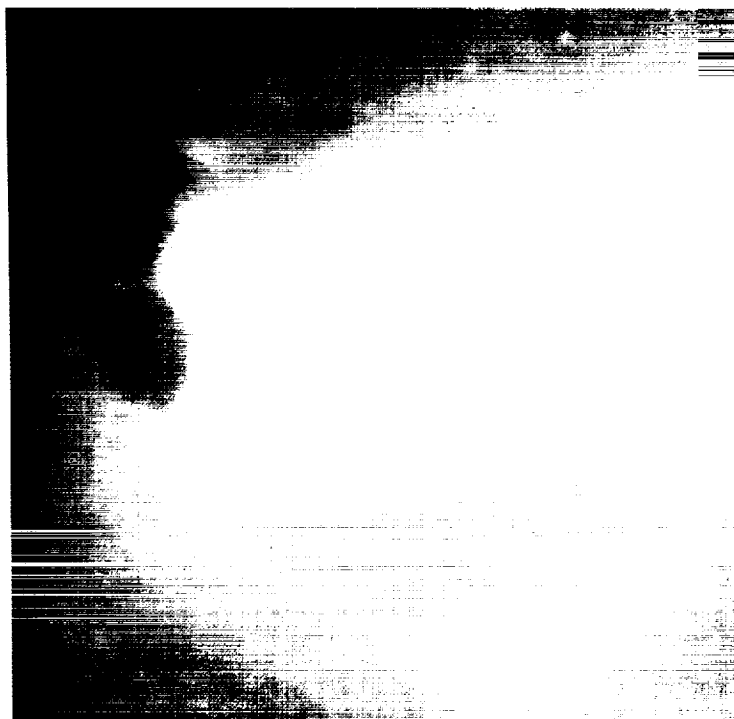

JANUARY 16-18, 1989
MILPITAS, CALIFORNIA

SPONSORED BY
LUNAR AND PLANETARY INSTITUTE
NASA AMES RESEARCH CENTER

(NASA-CR-184821) WORKSHOP ON ANALYSIS OF
RETURNED COMET NUCLEUS SAMPLES (Lunar and
Planetary Inst.) 98 p CACL 03B

N90-16607
--THRU--
N90-16656
Unclas

G3/90 0217836



Papers Presented to the

Workshop on

Analysis of Returned Comet Nucleus Samples

Milpitas, California

January 16-18, 1989

Sponsored by
Lunar and Planetary Institute
NASA Ames Research Center

LPI Contribution No. 691

Material in this volume may be copied without restraint for library, abstract service, educational, or research purposes; however, republication of any paper or portion thereof requires written permission from the author as well as appropriate acknowledgment of this publication.

* * * * *

Cover photo courtesy of H. U. Keller. Copyright held by Max-Planck-Institut für Aeronomie, Lindau-Katlenburg, FRG. Available from the Lunar and Planetary Institute as part of the Comet Halley image sequence (#C3443).

Preface

This volume contains abstracts that have been accepted by the Program Committee for presentation at the Workshop on Analysis of Returned Comet Nucleus Samples, held in Milpitas, California, January 16-18, 1989. Conveners are Sherwood Chang (NASA Ames Research Center) and Larry Nyquist (NASA Johnson Space Center). Program Committee members are Thomas Ahrens (ex-officio; California Institute of Technology), Lou Allamandola (NASA Ames Research Center), David Blake (NASA Ames Research Center), Donald Brownlee (University of Washington, Seattle), Theodore E. Bunch (NASA Ames Research Center), Humberto Campins (Planetary Science Institute), Jeff Cuzzi (NASA Ames Research Center), Eberhard Grun (Max-Planck-Institut fur Kernphysik), Martha Hanner (Jet Propulsion Laboratory), Alan Harris (Jet Propulsion Laboratory), John Kerridge (University of California, Los Angeles), Yves Langevin (University of Paris), Gerhard Schwehm (ESTEC), and Paul Weissman (Jet Propulsion Laboratory).

Logistics and administrative support for the workshop were provided by the LPI Projects Office.

This volume was prepared by the Publications Office of the Lunar and Planetary Institute, 3303 NASA Road One, Houston, Texas 77058-4399. The LPI is operated by the Universities Space Research Association under Contract No. NASW-4066 ✓ with the National Aeronautics and Space Administration.



TABLE OF CONTENTS

Analytical Study of Comet Nucleus Samples <i>A. L. Albee</i>	1
The Origin, Composition and History of Cometary Ices from Spectroscopic Studies <i>L. J. Allamandola</i>	3
Experimental Studies of Gas Trapping in Amorphous Ice and Thermal Modelling of Comets - Implications for Rosetta <i>A. Bar-Nun</i>	5
On the Isotope Analysis of Cometary Dust <i>F. Begemann</i>	8
Direct Determination of the Morphology, Structure and Composition of Cometary and Interstellar Ice Analogs in the Laboratory <i>D. F. Blake and L. J. Allamandola</i>	9
Electron Beam Analysis of Particulate Cometary Material <i>J. Bradley</i>	11
Thermal and Chemical Processing of the Outermost Layer of Cometary Nuclei <i>H. Campins and E. P. Krider</i>	12
The Carbon Chemistry of Meteorites: Relationships to Comets <i>S. Chang</i>	13
Laboratory Analyses of Micron-sized Solid Grains: Experimental Techniques and Recent Results <i>L. Colangeli, E. Bussoletti, A. Blanco, A. Borghesi, S. Fonti, V. Orfino, and G. Schwehm</i>	15
Analysis of Organic Compounds in Returned Comet Nucleus Samples <i>J. R. Cronin</i>	16
Non-Equilibrium Chemistry in the Solar Nebula and Early Solar System: Implications for the Chemistry of Comets <i>B. Fegley, Jr.</i>	18

Trace Element Abundance Determinations by Synchrotron X-ray Fluorescence (SXRF) on Returned Comet Nucleus Mineral Grains <i>G. J. Flynn and S. R. Sutton</i>	20
From Interstellar Dust to Comets <i>J. M. Greenberg</i>	22
Modifications of Comet Materials by the Sublimation Process: Results from Simulation Experiments <i>E. Grun and KOSI-team</i>	24
Comments on Comet Shapes and Aggregation Processes <i>W. K. Hartmann</i>	26
Cosmogenic Nuclides in Cometary Materials: Implications for Rate of Mass Loss and Exposure History <i>G. F. Herzog, P. A. J. Englert, and R. C. Reedy</i>	28
Morphology and Compositional Differentiation of the Surface of Comets <i>W. F. Huebner and D. C. Boice</i>	30
Role of Dust to Gas Production Rate Ratio in Cometary Physics <i>S. Ibadov</i>	31
Radiation Modification of Cometary Materials: Laboratory Simulations <i>R. E. Johnson</i>	32
Sulfur Compounds in Comets <i>S. Kim and M. A'Hearn</i>	33
Organic Chemistry of Cometary Dust as Derived from PUMA 1 Data <i>J. Kissel and F. R. Krueger</i>	35
Identification of Solar Nebula Condensates in Interplanetary Dust Particles and Unequilibrated Ordinary Chondrites <i>W. Klock, K. L. Thomas, and D. S. McKay</i>	36
Spectrophotometric Observations of Comet P/Giacobini-Zinner <i>I. Konno, S. Wyckoff, and P. A. Wehinger</i>	38
Composition of Dust from Comet P/Halley: The Mineral Fraction <i>Y. Langevin</i>	40

Computer Simulation of Dust Grain Evolution <i>K. Liffman</i>	41
Prompt Gamma Activation Analysis (PGAA): Technique of Choice for Nondestructive Bulk Analysis of Returned Comet Samples? <i>D. J. Lindstrom and R. M. Lindstrom</i>	43
Solar Nebula Condensates and the Composition of Comets <i>J. I. Lunine</i>	45
Candidate Sample Acquisition Systems for the Rosetta Mission <i>P. G. Magnani, C. Gerli, G. Colombina, and P. Vielmo</i>	47
Interstellar and Cometary Dust <i>J. S. Mathis</i>	48
The In-Situ Cometary Particulate Size Distribution Measured for One Comet: P/Halley <i>J. A. M. McDonnell and G. S. Pankiewicz</i>	50
Evolution of Carbonaceous Chondrite Parent Bodies: Insights into Cometary Nuclei? <i>H. Y. McSween, Jr.</i>	52
The Comet Rendezvous Asteroid Flyby Mission <i>D. Morrison, M. Neugebauer, and P. Weissman</i>	54
Measurements of Long-Lived Cosmogenic Nuclides in Returned Comet Nucleus Samples <i>K. Nishiizumi, C. P. Kohl, and J. R. Arnold</i>	56
Metamorphism of Cosmic Dust: Processing from Circumstellar Outflows to the Cometary Regolith <i>J. A. Nuth, III</i>	58
Microanalytical Characterization of Biogenic Components of Interplanetary Dust <i>F. Radicati di Brozolo, G. P. Meeker, and R. H. Fleming</i>	59
What if Chondritic Porous Interplanetary Dust Particles Are Not the Real McCoy? <i>F. J. M. Rietmeijer</i>	60

Handling and Analysis of Ices in Cryostats and Glove Boxes in View of Cometary Samples <i>K. Roessler, G. Eich, M. Heyl, H. Kochan, A. Oehler, A. Patnaik, W. Schlosser, and R. Schulz</i>	62
Trajectory-Capture Cell Instrumentation for Measurement of Dust Particle Mass, Velocity and Trajectory, and Particle Capture <i>J. A. Simpson and A. J. Tuzzolino</i>	64
Thermal Histories of the Samples of Two KOSI Comet Nucleus Simulation Experiments <i>T. Spohn, J. Benkhoff, J. Klinger, E. Grun, and H. Kochan</i>	66
Analysis of Particulates of Comet Nucleus Samples; Possible Use of Olivine as Indicator Phase <i>I. M. Steele</i>	68
The Nature of Cometary Materials <i>J. Stephens</i>	70
Methods for the Mineralogical and Textural Analysis of Comet Nucleus Samples <i>D. Stoffer, H. Duren, and J. Knolker</i>	71
Non-Destructive Trace Element Microanalysis of As-Received Cometary Nucleus Samples Using Synchrotron X-ray Fluorescence <i>S. R. Sutton</i>	73
Mechanical and SEM Analysis of Artificial Comet Nucleus Samples <i>K. Thiel, H. Kochan, K. Roessler, E. Grun, G. Schwehm, H. Hellmann, P. Hsiung, and G. Kolzer</i>	75
Electron Spin Resonance (ESR) Studies of Returned Comet Nucleus Samples <i>F.-D. Tsay, S. S. Kim, and R. H. Liang</i>	77
Ion Bombardment Experiments Suggesting an Origin for Organic Particles in Pre-Cometary and Cometary Ices <i>T. J. Wdowiak, E. L. Robinson, G. C. Flickinger, and D. A. Boyd</i>	79
Physical Processing of Cometary Nuclei <i>P. R. Weissman and S. A. Stern</i>	81

Contribution to Panel Discussion on the Material Returned from a Comet <i>E. Whalley</i>	83
Refractory Solids in Chondrites and Comets: How Similar? <i>J. A. Wood</i>	84
Isotopic Microanalysis of Returned Comet Nucleus Samples <i>E. Zinner</i>	86
The Measurement of Trace Elements in Interplanetary Dust and Cometary Particles by Ultra-high Sensitivity INAA <i>M. E. Zolensky, D. J. Lindstrom, R. M. Lindstrom, and M. M. Lindstrom</i>	88



553882
p. 2

ANALYTICAL STUDY OF COMET NUCLEUS SAMPLES; A. L. Albee,
California Institute of Technology, 02-31, Pasadena, CA 91125.

The detailed analytical study of the Apollo lunar samples revolutionized our understanding of Moon. In addition, the analytical challenge demonstrated the capabilities of a variety of new instrumental techniques for providing precise analysis of very small samples. Electron-beam instruments with imaging and analysis capabilities, x-ray fluorescent analysis, instrumental neutron activation analysis, and high-resolution mass spectroscopy are all now considered as standard techniques.

Study of comet nucleus samples will be even more challenging, calling upon all of the standard techniques that are now used to study meteorites as well as upon new techniques that can address the special properties of these samples. Most of the lunar samples were rocks and rock fragments differing from terrestrial samples mainly in the small size of the samples. However, study of the core samples required special techniques for their dissection and analysis.

Current plans call for the return of frozen (130 K) core samples from the nucleus. Based on a variety of evidence it is believed that this ice rock sample will consist of a variety of grains cemented by interstitial icy phases. These grains will include: 1) single grains of silicate, oxide, and sulfide minerals; 2) very fine-grained aggregates of poorly-crystallized phyllosilicates; 3) clumps of "tarry" (CHON) compounds; 4) composite grains of the same constituents, including "tarry" coatings. The interstitial ice may include clathrates, as well as ice phases of H_2O , CO_2 , NH_3 , etc.

At our present level of technology each of these components requires different analytical approaches, preparation, and instrumentation to achieve adequate results. Even with new approaches it will probably be necessary to separate the components for thorough study. However this should be done only after study of the bulk core clarifies the spatial relationships and the identity of the various components. By external study of the core at cryogenic temperatures we should be able to determine the structures and bulk chemistry of the core, the fabric as exposed on its surface, and the identity of the ice phases and of representative non-volatile grains. It should be possible to obtain non-destructive 3-dimensional imaging of the core at several wavelengths ranging from sonic to x-rays. The bulk composition can be determined by neutron-activated gamma ray spectroscopy. The surface of the core can be photographed with an optical microscope and elemental composition can be obtained from electron and ion-beam analysis. Each such procedure must be considered in terms of side-effects that may be deleterious to other analyses. Identification of the ice phases and preliminary analysis of tarry material will probably require removal of small samples.

ANALYTICAL STUDY OF COMET NUCLEUS

Albee, A. L.

This preliminary information will be used to design a handling scheme that can be tested on a portion of the core. Cutting the core will provide additional smooth surfaces for examination. A thin slice of core can be imaged in transmission and the ices removed by a step-wise controlled devolatilization that will differentially remove the various ice phases. Complete volatilization below the freezing point of water will leave the grains in their original position relative to one another for documentation prior to removal for detailed study. Elemental, isotopic, and mineralogic study of the individual grains and their coatings can be carried out by several methods at very high precision, even with current techniques.

But, we will be surprised! We can be certain that this model is far too simple. The interstitial ice may be lost on the return trip, leaving only a loose aggregate of grains in an atmosphere reflecting the ice composition. Or the core may never have contained any interstitial ice--only a compacted aggregate of residual grains from the near surface of the comet. The nature of the grains may be quite different--more variety or only a single type. The design of the core tube must allow for some external examination and varied modes of core removal must be well understood. A variety of worse-case scenarios must be designed and practiced in advance of the sample return.

THE ORIGIN, COMPOSITION AND HISTORY OF COMETARY ICES FROM SPECTROSCOPIC STUDIES; L. J. Allamandola, Space Science Division, NASA-Ames Research Center, Moffett Field, California 94035

The spectroscopic analysis of pristine cometary material provides a very important probe of the chemical identity of the material as well as of the physical and chemical conditions which prevailed during the comet's history. Concerning classical spectroscopy, the spectral regions which will most likely prove most useful are the infrared, the visible and ultraviolet. "Newer" spectroscopic techniques which have the potential to provide equally important information include nuclear magnetic resonance (NMR) and electron spin resonance (ESR).

This talk will summarize each "spectroscopy" with emphasis placed on the kind of information which can be obtained from each technique. The infrared should be the premier method of analysis as the mid-infrared absorption spectrum of a substance contains more global information about that substance's identity and structure than any other property. It was for this reason that the tabletop IR spectrometer quickly became the workhorse for industrial chemical analytical laboratories and has remained so for over forty years. The greatest strides in our understanding of the composition of interstellar ices, thought by many to be the primordial material from which comets have formed, have been taken during the past ten years or so, the period of time in which high quality infrared spectra of the interstellar medium have become available.

It must be kept in mind however that the interpretation of the infrared spectra of mixtures such as expected in comets is often (not always) ambiguous. Other non-destructive, complementary, spectroscopic measurements are required to characterize the material and probe for substances for which the infrared is not particularly well suited. While the mid- and far-IR span frequencies which correspond to skeletal vibrations in molecules and thus provide insight into the identity of chemical groups present, the ultraviolet, visible and near infrared span frequencies which correspond to electronic transitions and give insight into the molecular bonding structures present. In these regions absorption and emission studies are desirable. Absorption measurements have the potential to give an indication of the importance of conjugated bond systems, although sample porosity will almost certainly make the measurements difficult. More tractable will be luminescence studies. Measuring the luminescence excited by ultraviolet and visible photons should be straightforward. The spectrum of the emission, as well as the wavelength dependence of the exciting light give important insight into the nature of emitting materials. In addition to UV-Vis induced luminescence, thermally promoted chemiluminescence should also be searched for. Irradiation of solid materials often produces trapped ions, electrons and radicals which can diffuse through the medium if it is warmed. Reactions involving these diffusing species often give off a spectrum which is characteristic of the reacting species. The temperature domain over which light is emitted depends on the nature of the solid. Volatile rich ices luminesce in the 10-40K range, H₂O rich ices in the 10-150K range and higher melting point materials luminesce at much higher temperatures. Thus the monitoring of potential luminescence during core drilling and during subsequent sample warm-up is important to consider seriously as it can provide unique information on the thermal and radiation history of the sample which cannot be obtained in any other way.

Three additional spectroscopic techniques will also be summarized: Raman, NMR and ESR. Raman spectroscopy is complementary to IR spectroscopy in that it probes the vibrational frequencies of the material. It is not redundant. A good example of the power of the two techniques is provided by the spectra of interplanetary dust particles. The infrared spectra give information about the mineral components, while the Raman spectra

probe the carbon. NMR studies can tell what the fractions are of various classes of organic compounds and ESR studies can directly measure the total radical content in the ice.

N90-16610EXPERIMENTAL STUDIES OF GAS TRAPPING IN AMORPHOUS ICE AND
THERMAL MODELLING OF COMETS - IMPLICATIONS FOR ROSETTA

Akiva Bar-Nun, Department of Geophysics and Planetary Sciences,
Tel Aviv University, Tel Aviv, 69978, Israel.

The trapping of mixtures of CO, CH₄, N₂ and Ar in amorphous water ice was studied experimentally, by flowing 1:1 gas: water vapor mixtures at 2×10^{-5} Torr onto a cold plate at 25 - 100K. This mixture was used, since the ratio (CO+CH₄)/H₂O vapor in the solar nebula was close to 1. The amount of trapped gas in the ice was found to drop by 6 orders of magnitude between deposition temperatures of 25 and 100K. Hence, the gas content of comets can serve as a very sensitive cosmo-thermometer. It was found that in order to trap 3.5% (parent) CO in the ice, as found for comet Halley, the comet had to be formed at 48 ± 5 K. CH₄ was found to be trapped in the ice ~100 times more efficiently than CO. Hence, in order to trap in Halley's ice 3.5% CO and only ~1% CH₄, the CO/CH₄ ratio in the region of Halley's formation had to be ~100.

The ice particles could not have been formed at a higher temperature and, subsequently, cool down. Experiments where ice was deposited at elevated temperatures, then cooled down and gas was flowed into the ice, showed that the amount of trapped gas depends only on the highest temperature at which the ice was formed, or resided, prior to cooling and gas flow into it. Consequently, the cometary ice had to be formed at ~48K and the ice is therefore amorphous.

Duncan et al. (1988) and Delsemme (1988) propose that the short period comets were formed in an extended dust shell - the "Kuiper

Belt,"— at $\sim 40\text{K}$ and remained there unperturbed, whereas the long period comets were formed in the Uranus - Neptune region, at $\sim 80\text{K}$, and were ejected from there into the Oort cloud. Similar circumstellar dust shells were found by IRAS to have the following temperatures: α P_SA - 55K; ϵ Eri - 45K; α Lyr - 85K and β Pic 100K. In the first two, comets with Halley's gas content can be formed whereas in the last two the gas content would be $\sim 10^{-4}$ - 10^{-5} .

Similar experimental studies were carried out on the trapping of the noble gases Ar: Kr: Xe = 10,000: 8:1 (like in the solar nebula) at 50- 75K. They showed that the enrichment factors earth/solar: Kr/³⁶Ar = 74 and Xe/³⁶Ar = 48, can be obtained by bringing these gases to earth by comets which were formed at ~ 50 - 55K . If all the terrestrial ³⁶Ar, Kr and Xe were delivered only by such comets, the amount of water delivered by them should have been $\sim 10^{-4}$ of the total amount of free and bound water ($\sim 2 \times 10^{24}$ g). A hundred fold dilution of the noble gases by CO did not alter these enrichment factors.

The thermal profile of a comet in Halley's orbit was calculated, including the build-up of an insulating dust layer. It was found that an insulating dust layer few cm thick is enough to choke most of the water emission from the surface. Also, a layer about 40 m thick of crystalline ice is formed at the surface by solar heating above 137K - the temperature of transformation from amorphous to cubic ice. During this transformation, large quantities of trapped gases are released from the amorphous ice and accumulate in pockets in the crystalline ice. Explosions of these pockets can explain the sporadic small explosions, which were observed on Halley from the ground, as well as the formation of the large active craters which were photographed by

Giotto's camera.

A similar thermal model was calculated for comet P/Temple-1, a candidate for both CRAF and Rosetta (CNSR) missions. The temperature at a depth of 10 m is ~160K for all models considered and, hence, the ice at this depth is crystalline. A crystalline ice layer 40-240 m thick (depending upon the parameters used) was found to overly the gas-laden amorphous ice. Consequently, it should be difficult for the probes of the two comet missions to sample pristine amorphous ice, unless they are aimed at the bottom of an active crater.

ON THE ISOTOPE ANALYSIS OF COMETARY DUST:
Friedrich Begemann, Max-Planck-Institut für Chemie, Mainz, FRG.

Common lore has it that comets are an intimate mixture of ices and sub-micron to pebble sized silicates. Based on experience with carbonaceous chondrites part of the smallest grains are expected to be primary condensates carrying the unadulterated isotopic signature of their place of origin. In order to extract this information a grain-by-grain analysis will be necessary. In the case of pebbles it will be important to unravel their thermal and irradiation history prior to their incorporation into comets which again requires that minute amounts of complex material must be analyzed. As far as the isotopic analysis by "classical" mass spectrometry is concerned the factors determining the minimum amounts of material required are background problems, ion yields and ion production rates. Lines to be pursued would appear to be data acquisition by multi-collectors on directly loaded samples, aiming at what has been reached with noble gases where more than 50% of all atoms from a given sample can be detected. What needs to be developed in addition are means to recognize and pool grains of common origin, similar to what is done with great success, albeit with brute force, on certain rare constituents of meteorites.

Isotope and nuclide pairs will be discussed which appear to be suited to determine the time of separation of cometary matter from interstellar matter and to determine times of isotopic equilibration with particular emphasis on problems anticipated from small grain sizes.

DIRECT DETERMINATION OF THE MORPHOLOGY, STRUCTURE AND COMPOSITION OF COMETARY AND INTERSTELLAR ICE ANALOGS IN THE LABORATORY;
D.F. Blake, and L.J. Allamandola, SETI Institute, 101 First St., #410, Los Altos, CA 94022 and MS 245-6, NASA/Ames Research Center, Moffett Field, CA 94035

Ices of various kinds (H_2O , CO, CO_2 , CH_4 , NH_3 , CH_3OH , etc.) comprise a volumetrically significant proportion of objects in the solar system (comets, outer planets, planetary rings, satellites) as well as in interstellar space (astrophysical ices). Despite their widespread occurrence, few experimental data exist which address the phase equilibria and possible structure states of solar system and interstellar ices.¹ An understanding of the petrology of cometary and astrophysical ice analogs will allow a more confident interpretation of remote IR observations of comets, cold molecular clouds and the like. Furthermore, the refinement of procedures for storing, preparing and analyzing ices and other materials at cryogenic temperatures is essential to the successful analysis of returned comet nucleus samples.

A great deal is already known about the microstructural characteristics of water ice and frozen dilute solutions through Analytical Electron Microscopy (AEM). Dubochet et al.², for example, report on AEM observations of pure water ice and dilute solutions of salts and organic material. Figure 1, a-d shows bright field and dark field TEM images, selected area electron diffraction, and elemental analysis data for pure water ice (cubic polymorph) grown in an Hitachi H-500 AEM at 120° K. The source of the water ice condensed on the stage is the vacuum system in this case but these results show that chemical, morphological and phase information can be obtained at high spatial resolution from such samples.

We are presently modifying our microscope so that gas samples of selected compositions can be introduced into the specimen area and frozen onto the sample stage for observation and analysis. Identical gas samples will be frozen and characterized using infrared spectroscopy (IR) in the Low Temperature Spectroscopy Laboratory (LTSL) at Ames Research Center. An additional suite of analyses are planned using ices grown and processed by UV in the LTSL, and transferred at 100° K into the AEM.

All of the present analyses will be conducted at 100° K and above due to AEM stage limitations. However, we anticipate the acquisition and installation of a 20° K specimen stage into the microscope by early next year. This will allow the study of ices grown in the temperature regime of cold interstellar clouds, and permit the ultrastructural, morphological and microchemical analysis of selected ice compositions for which a large body of IR data exist.³

Lastly, one of the limitations of conventional AEM is that specimens can be no thicker than 100-300 nm or so in order to be electron transparent. Since we would like to perform analyses on aliquots from bulk ice samples, we are developing procedures for the routine use of cryoultramicrotomy in sample preparation. Using this technique, it is possible to cut thin samples of ice (20-200 nm thickness) which are then transferred into the microscope for analysis. It is anticipated that this will be an important technique for the preparation of thin sections of returned comet nucleus material.

1. Smeluchowski, R. (1983). *Science*, **222**, 161-163.
2. Dubochet, J., J. Lepault, R. Freeman, J.A. Berriman and J.C. Homo (1982). *J. Microscopy*, **128:3**, 219-237.
3. Sandford, S.A., L.J. Allamandola, A.G.G.M. Tielens and G.J. Varlero (1988). *Astrophys. Jour.*, **329**: 498-510.

Figure 1. AEM of ice crystals nucleated onto a thin (~10 nm) holey carbon film substrate. The substrate was maintained at 120° K (-153° C) for approximately 3 hours, during which time, water vapor present inside the microscope at the mid-10⁻⁷ torr level, condensed onto the cold substrate.

(a). Bright field TEM image of ice crystals nucleated onto a 120° K holey carbon film substrate. Large bright areas are holes in the carbon film. "Lumpy" dark areas are individual crystals of water ice. Magnification, 100,000 X.

(b). Dark field TEM image of same area as (a) above. Bright grains are individual crystals of water ice which are in proper orientation for diffraction. Individual crystals are 5 - 50 nm in size.

(c). Electron diffraction pattern of submicron area of (a) above. Debye-Scherrer rings index as the cubic polymorph of water ice (Ic, (111), (220), and (311) rings labelled).

(d). Elemental analysis of submicron area of (a), above. The detector is sensitive to all elements above Be in atomic number which are present in 1% or greater concentration. While this is a trivial example since only O and trace C (from the support) are detected, in mixed ices N from NH₃ and C from CH₄ or CH₃OH would be detected as well.

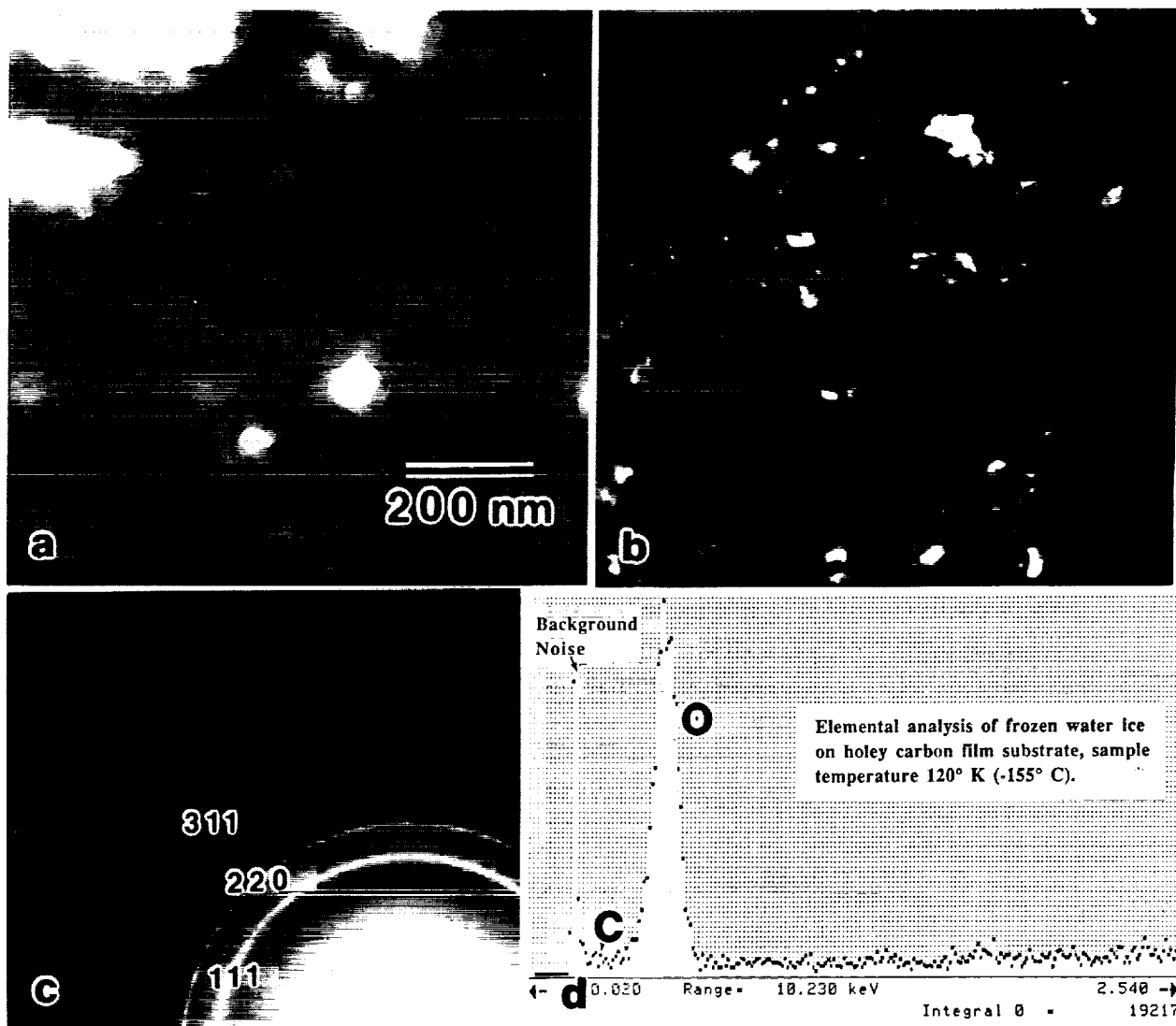

ELECTRON BEAM ANALYSIS OF PARTICULATE COMETARY MATERIAL

John Bradley, McCrone Associates

Westmont, IL 60559

Electron microscopy will be useful for characterization of inorganic dust grains in returned comet nucleus samples. The choice of instrument(s) will depend primarily on the nature of the samples, but ultimately a variety of electron-beam methods could be employed. Scanning and analytical (transmission) electron microscopy are the logical choices for morphological, mineralogical, and bulk chemical analyses of dust grains removed from ices. It may also be possible to examine unmelted ice/dust mixtures using an environmental scanning electron microscope (SEM) equipped with a cryo-transfer unit and a cold stage. Electron microscopy offers the potential for rapid evaluation of the relationship between a comet nucleus sample and meteoritic materials. Interplanetary dust particles (IDP's) are the most likely meteoritic analog and they are known to be fragile aggregates of extremely fine-grained material. Assuming comet nucleus samples are similar, electron microscopic characterization could include morphological examination and bulk chemical analysis in the SEM, thin-sectioning by ultramicrotomy, and automated thin-film analysis in an analytical electron microscope (AEM). Automated analyses generate large data sets of quantitative chemical information which can be compared with existing data bases from IDP's and carbonaceous chondrites. Additional electron microscopic observations of comet nucleus material might include determination of: a) porosities of dust grains (are they similar to IDP's?); b) morphologies and microstructures of individual mineral grains (is there evidence for gas-to-solid condensation?); c) relative abundances of olivine, pyroxene, and glass (how do these compare with infrared spectral signatures?); d) the presence or absence of phases that might have resulted from aqueous alteration (layer silicates, carbonates, sulfates).

THERMAL AND CHEMICAL PROCESSING OF THE OUTERMOST LAYER OF
COMETARY NUCLEI; Humberto Campins (Planetary Science Inst./SAIC) and
E. Philip Krider (Univ. of Arizona)

A non-equilibrium mechanism that may produce substantial thermal and
chemical processing of the outermost layer of cometary nuclei is proposed.
If this phenomenon does occur, its effects will impact the interpretation
of results from the CNSR and CRAF missions.

THE CARBON CHEMISTRY OF METEORITES: RELATIONSHIPS TO COMETS
S. Chang, NASA Ames Research Center, Moffett Field, CA 94035

The carbonaceous meteorites exhibiting extensive alteration by liquid water bear a strong relationship to comets. Not only is their elemental composition closer to solar in relative abundances than other meteorites, they are water rich; and they contain isotopic compositions among refractory and volatile elements indicative of presolar components. Some of these isotopic anomalies occur in organic compounds and carbonaceous grains signifying the presence of discrete and identifiable carbon components derived from interstellar and circumstellar matter. Insofar as comets and meteorites are ultimately formed from interstellar gas and dust, and comets have been subjected to considerably less aqueous and thermal evolution than carbonaceous meteorites, the interstellar imprint should be much stronger and better preserved in comets.

The organic matter that can be extracted from carbonaceous meteorites by solvents is structurally diverse and exhibits a wide range of isotopic compositions for H, C and N. Many classes of compounds occur, ranging from simple hydrocarbons to polycyclic heteroaromatics with multiple functional groups, including aromatic hydrocarbons, aldehydes, ketones, amines, amino acids, carboxylic acids, and purines among others. The simplest homologues of several of these classes have been observed in comets and giant molecular clouds.

Among the amino acids alone, about 30 discrete stereochemical structures have been identified, and at least 20 remain unidentified. No single production mechanism [e.g., electric discharges, Fischer-Tropsch Type (FTT) synthesis, uv-irradiation, energetic ion irradiation, HCN polymerization and hydrolysis, Strecker synthesis], nor any single environment of synthesis (i.e., solar nebula, molecular cloud, parent body) has yet been able to account for the observed variation in structures and abundances. The overall diversity of the organic compounds argues strongly for multiple sources and synthesis mechanisms. This conclusion is substantiated by the wide variations observed in the isotopic compositions of H (~1500 o/oo), C (~60 o/oo), and N (~90 o/oo) contained in the extractable organics. Notably, the deuterium enrichments in the amino and carboxylic acids are attributable to incorporation of D-rich interstellar molecules during synthesis of the acids. Indicators uniquely characteristic of nebular or parent body origins are not yet apparent.

Significant abundances of organic compounds and wide variations in their molecular structures and isotopic compositions appear to be restricted to those meteorites composed of mineral assemblages resulting from extensive alteration by liquid water. This water may have been accreted directly on the parent body as water ice during a nebular condensation sequence or it may have been carried to the parent body in the form of cometesimals during accretion. The former scenario entails FTT and other disequilibrium syntheses in the nebula to account for the organic compounds, which conflicts with the observed deuterium enrichments and isotopic variations in C and N in the organic matter, as well as with the relative abundances of highly volatile simple hydrocarbons in the meteorite samples. The favored latter scenario delivers to the meteorite parent body relatively large icy reservoirs (possibly up to km in diameter) of volatile and refractory organic interstellar components

accreted elsewhere and preserved at low temperatures.

Mobilization of liquid water in carbonaceous meteorite parent bodies altered the mineralogy of pre-existing anhydrous mineral assemblages. In analogous fashion, thermally or water labile nebular species previously accreted or interstellar molecules (e.g., free radicals, cyanopolyynes, ketenes) accreted in cometary ices, would also have undergone chemical changes on the parent body when the ice melted and aqueous reactions could occur in the presence of mineral surfaces. For example, some of the amino and carboxylic acids now found in meteorites may have been formed by hydrolysis of precursive nitriles; some may have been synthesized by the Strecker route from ammonia, HCN and simple aldehydes. Analyses of returned comet nucleus samples should be conducted at temperatures no higher than those experienced by the sample during acquisition and return to Earth in order to prevent further alteration of labile compounds. In addition to the roster of known interstellar molecules, the low temperature characterization of organic compounds formed in simulations of astrophysical processing of interstellar and cometary dust and gas should provide valuable guidelines as to what may be found in comet samples.

A small fraction of meteoritic carbonaceous grains have also been implicated as interstellar in origin either by isotopic anomalies in the C, N, and Si of which they are comprised or by their contents of isotopically noble gases. These minor components include diamond, SiC, and several poorly characterized forms of elemental carbon.

The structure of the bulk of the solid carbonaceous grains, which accounts for most of the carbon in the meteorites (the so-called kerogen or polymer), is also poorly characterized. The grains are obtained as sub-micron to micron-sized clumps of smaller particles by dissolving the meteorite sample in acids. Depending on the petrologic type of carbonaceous meteorite, this solid material appears to vary in its proportions of amorphous (aliphatic) to poorly ordered turbostratic (aromatic) to highly ordered turbostratic structures. Mixed with amorphous regions are tangled ribbon-like structures with microcrystallite dimensions ranging from tens to hundreds of angstroms. This material exhibits minor variations in carbon isotopic composition, significant enrichments in N¹⁵, and large enrichments in deuterium. The apparently interstellar deuterium enrichment is preserved in both aliphatic and aromatic moieties. How much of the structural and isotopic variation in this material is the result of nebular or parent body processes is unclear. Spectroscopic similarities with interstellar polycyclic aromatic hydrocarbons have been pointed out, and analogies with the CHON particles of Comet p/Halley are obvious. Similar grains with possibly higher proportions of amorphous material should occur in comets. Furthermore, one might predict that organic matter will be found intermediate in molecular weight between the solvent extractable compounds and the solid carbon phases.

Usually these carbon phases are isolated after extensive chemical treatments of bulk meteorite samples; and they are analyzed as agglomerates, largely because the individual grains are extremely small and the isolation process yields aggregates. In comets, however, they may occur dispersed among ice grains, which could allow structure and composition to be determined at the level of individual particles. Thus individual core-mantle particles and curved sheets of polycyclic aromatic structure may be found, as have been postulated for interstellar dust. Some evidence of such structures has been obtained from study of the Orgueil meteorite.

LABORATORY ANALYSES OF MICRON-SIZED SOLID GRAINS: EXPERIMENTAL TECHNIQUES AND RECENT RESULTS; L. Colangeli ⁽¹⁾, E. Bussoletti ⁽²⁾, A. Blanco ⁽³⁾, A. Borghesi ⁽³⁾, S. Fonti ⁽³⁾, V. Orofino ⁽³⁾, G. Schwehm ⁽¹⁾; ⁽¹⁾ Space Science Department of ESA, ESTEC, Noordwijk (The Netherlands), ⁽²⁾ Istituto Universitario Navale, Napoli (Italy), ⁽³⁾ Physics Department, University of Lecce, Lecce (Italy)

Morphological and spectrophotometric investigations have been extensively applied in the past years by our group to various kinds of micron and/or submicron-sized grains formed by materials which are candidate to be present in space. The samples have been produced in the laboratory and then characterized in their physico-chemical properties ⁽¹⁾.

Transmission (T.E.M.) and scanning (S.E.M.) electron microscopy give useful information about size, shape and surface status of the grains, and diffraction methods are applied to determine the degree of crystallinity ⁽²⁾. Spectrophotometric measurements are performed to identify the absorption properties of the samples, all over the spectral range from vacuum ultraviolet (VUV) to far infrared (FIR). Conventional double beam spectrophotometers and interferometers are used to cover the wavelength range from 2000 Å to 300 μm ⁽¹⁾. The optical properties in the VUV - up to 1100 Å - are determined by using the "Adone" and "Bessy" synchrotron light facilities, in Frascati (Italy) and Berlin (West Germany), respectively ^(3,4).

Here we report some of the most recent results obtained on various kinds of carbonaceous materials. Main attention is devoted to spectroscopic results in the VUV and IR wavelength ranges, where many of the analyzed samples show typical "fingerprints" which can be identified also in astrophysical and cometary materials.

The laboratory methodologies used so far are also critically discussed in order to point out capabilities and present limitations, in the view of possible application to returned comet samples. Suggestions are given to develop new techniques which should overcome some of the problems faced in the manipulation and analysis of micron solid samples, and unsolved, so far.

- (1) Bussoletti, E., Colangeli, L., Borghesi, A. and Orofino, V. (1987) Astr. Ap. Suppl. Ser. 70, 257-268.
- (2) Borghesi, A., Bussoletti, E. and Colangeli, L. (1985) Astr. Ap. 142, 225-231.
- (3) Colangeli, L., Capozzi, V., Bussoletti, E. and Minafra, A. (1986) Astr. Ap. 168, 349-353.
- (4) Blanco, A., Borghesi, A., Bussoletti, E., Colangeli, L., Fonti, S., Gumlich, H. E., Jung, Ch., Orofino, V. and Schwehm, G. (1988) in Interstellar Dust, IAU Symp. 135, in press.

ANALYSIS OF ORGANIC COMPOUNDS IN RETURNED COMET NUCLEUS SAMPLES;
J.R. Cronin, Department of Chemistry, Arizona State University, Tempe, AZ
85287-1604

Comets are widely held to be the most primitive solar system bodies, that is, they are believed to contain solar system matter in, or nearly in, its primordial state. In the limit, comets may contain a low-temperature condensate representative of the precursive dust and gas cloud. However, there are reasons to believe that cometary matter has been processed while in the Oort cloud and during excursions into the inner solar system. Again in the limit, this processing may have converted the original constituents at least partially to chondrite-like material. Various intermediate stages between these extremes can also be envisioned. The organic analyst must be prepared for analytes characteristic of each of these possibilities, i.e., interstellar, chondritic, and transitional organic species.

The interstellar component may have contributions from both the gas phase (1) and grain mantles (2). Analysis of the condensed gas phase components is complicated by the fact that many are unstable radicals or ions, or stable molecules that will rapidly react with each other or their matrix components upon warming. This fact dictates sampling, sample return, and storage at low temperature and analysis in the solid state, e.g., by electron spin resonance and ion-beam techniques.

Chondritic organic matter has been the subject of extensive analyses over the past 20 years (3). CM and CI chondrites have been found to contain most of their carbon as an insoluble macromolecular material with both aromatic and aliphatic components as well as various organic functional groups. The CM and perhaps CI chondrites contain, in addition, a complex mixture of discrete, molecular species, e.g., hydrocarbons, carboxylic acids including amino acids, and nitrogen heterocycles including purines and pyrimidines. Recent stable isotope analyses have shown that these organic molecules (4), along with a fraction of the macromolecular carbon (5), are enriched in deuterium. This finding has been interpreted as indicating a genetic relationship with interstellar molecules (6). Furthermore, several observations are consistent with the formation of chondritic organics from interstellar precursors by hydrothermal processes: (a) abundant organic molecules occur only in chondrites with hydrated silicate matrices; (b) amino acid abundance follows the content of the so-called "poorly characterized phases" (PCP) which is thought to be an early product in the aqueous alteration process (7); (c) amino acid/hydroxy acid ratios suggest their formation by aqueous phase Strecker synthesis (8); (d) facile aqueous phase reactions exist which could account for the conversion of interstellar molecules to many other chondritic organics. Any evidence for the occurrence of aqueous phases in cometary nuclei, e.g., the identification of hydrous silicate minerals, will suggest the occurrence of the more complex, stable organic molecules characteristic of carbonaceous chondrites and dictate that appropriate liquid chromatographic, gas chromatographic, and combined gas chromatographic-mass spectrometric methods be developed.

Appropriate sampling procedures will be essential to the success of these analyses. It will be necessary to return samples that represent all the various regimes found in the nucleus, e.g., a complete core, volatile components (deep interior), and crustal components (surface minerals, rocks, processed organics such as macromolecular carbon and polymers). Furthermore, sampling, storage, return, and distribution of samples must be done under conditions that preclude contamination of the samples by terrestrial matter.

References:

1. Irvine, W.M. and Hjalmarson, A. (1984) Origins of Life 14, 15-23.
2. Greenberg, J.M. (1982) in Comets, Wilkening, L., ed., pp. 131-163, Univ. Ariz. Press.
3. Cronin, J.R., Pizzarello, S. and Cruikshank, D. (1988) in Meteorites and the Early Solar System, Kerridge, J. and Mathews, M., eds., in press, Univ. Ariz. Press.
4. Epstein, S., Krishnamurthy, R.V., Cronin, J.R., Pizzarello, S. and Yuen, G.U. (1987) Nature 326, 477-479.
5. Robert, F. and Epstein, S. (1982) Geochim. Cosmochim. Acta 46, 81-95.
6. Kolodny, Y., Kerridge, J.F. and Kaplan, I.R. (1980) Earth Planet Sci. Lett. 46, 149-158.
7. Cronin, J.R. (1988) Adv. Space Res., in press.
8. Peltzer, E.T., Bada, J.L., Schlesinger, G. and Miller, S.L. (1984) Adv. Space Res. 4 (#12), 69-74.

NON-EQUILIBRIUM CHEMISTRY IN THE SOLAR NEBULA AND EARLY SOLAR SYSTEM: IMPLICATIONS FOR THE CHEMISTRY OF COMETS Bruce Fegley, Jr., Department of Earth, Atmospheric, and Planetary Sciences, Massachusetts Institute of Technology, Cambridge, MA 02139 USA

Theoretical models of solar nebula and early solar system chemistry which take into account the interplay between chemical, physical, and dynamical processes have great utility for deciphering the origin and evolution of the abundant chemically reactive volatiles (H, O, C, N, S) observed in comets. In particular, such models are essential for attempting to distinguish between presolar and solar nebula products and for quantifying the nature and duration of nebular and early solar system processing to which the volatile constituents of comets have been subjected. This talk will focus on the diverse processes and energy sources responsible for chemical processing in the solar nebula and early solar system. The processes to be considered include homogeneous and heterogeneous thermochemical and photochemical reactions, and disequilibrium resulting from fluid transport, condensation, and cooling whenever they occur on timescales shorter than those for chemical reactions. The energy sources to be considered include the thermal energy of the nebula, shock waves and photons from lightning discharges, proto-solar and stellar photons, and radioactive decay processes. Plausible models for the chemical compositions of gases and volatile-bearing grains as a function of space and time in the nebula and in subnebulae around the giant planets will be discussed.

Some conclusions of this theoretical modelling (e.g., see Fegley, 1988; Fegley and Prinn, 1988; Prinn and Fegley, 1988) include the following:

1. Non-equilibrium chemistry was responsible in large part for establishing the chemical speciation in the solar nebula and in subnebulae around the giant planets.
2. The dominant carbon and nitrogen gases in the solar nebula were CO and N_2 . This is probably similar to the situation in the interstellar medium where observations and theoretical models imply that CO and N_2 also dominate the gas phase carbon and nitrogen inventories. In contrast, the dominant carbon and nitrogen gases in giant planet subnebulae were CH_4 and NH_3 .
3. Fe metal grains in the solar nebula catalyzed the formation of organic compounds from nebular $CO + H_2$ via Fischer-Tropsch-type reactions. On the order of 10% of the total CO inventory was converted into organic compounds, in this fashion.
4. Hydrated silicate formation was kinetically inhibited in the solar nebula, but was kinetically favorable in the subnebulae around giant planets. Any hydrated silicates observed in comets, therefore, are *not* solar nebula products.
5. Formation of FeS by the sulfurization of Fe metal grains was kinetically favorable in the solar nebula. In contrast, FeO incorporation into silicates at low

temperatures (e.g., as predicted by canonical equilibrium condensation models) and *bulk* Fe_3O_4 formation were both kinetically inhibited in the solar nebula.

6. Clathrate formation (e.g., CO and N_2 clathrates) was kinetically inhibited in the solar nebula but CH_4 clathrate formation was kinetically favorable in the subnebulae around giant planets.
7. The CO/CH_4 and N_2/NH_3 ratios in comet P/Halley are intermediate between those ratios in the solar nebula ($CO/CH_4 \gg 1$ and $N_2/NH_3 \gg 1$) and in giant planet subnebulae ($CO/CH_4 \ll 1$ and $N_2/NH_3 \ll 1$). These intermediate ratios are most plausibly produced by a two component mixing model in which CO -, N_2 -rich material from the solar nebula (and/or from the interstellar medium) is mixed with a smaller amount of CH_4 -, NH_3 -rich material from subnebulae around the giant planets.
8. Non-equilibrium processing due to lightning discharges and photochemistry driven by stellar photons were potentially significant chemical reprocessing mechanisms in the outer solar nebula. In contrast, photochemistry driven by solar photons was unimportant in the very hot, thermochemically-controlled inner nebula. Absorption by gas and dust also limited severely the importance of solar UV photochemistry in the outer regions of the solar nebula. Dust absorption played a similar limiting role during early solar system history.
9. Deuterium-to-hydrogen ratios significantly higher than the canonical primordial value of $D/H \sim 2 \times 10^{-5}$ (e.g., the terrestrial $D/H \sim 1.6 \times 10^{-4}$) cannot be produced by low temperature equilibration in the solar nebula.

These conclusions, as well as their implications for the chemistry of comets will be discussed in more detail at the meeting. Recommendations for specific tests of these implications will also be made.

References

- Fegley, B., Jr. 1988 in *Workshop on the Origins of Solar Systems*, LPI Technical Report No. 88-04, pp. 51-60.
- Fegley, B., Jr. and Prinn, R. G. 1988 in *The Formation and Evolution of Planetary Systems* (eds. H. A. Weaver, F. Paresce and L. Danly), Cambridge Univ. Press, in press.
- Prinn, R. G. and Fegley, B., Jr. 1988 in *Origin and Evolution of Planetary and Satellite Atmospheres* (eds. S. Atreya, J. Pollack, and M. S. Matthews), Univ. of Arizona Press, in press.

Acknowledgements

This research was supported by NASA Grants NAG9-108 (Planetary Materials and Geochemistry) and NAGW-997 (Planetary Atmospheres) to MIT.

TRACE ELEMENT ABUNDANCE DETERMINATIONS BY SYNCHROTRON X-RAY FLORESCENCE (SXRF) ON RETURNED COMET NUCLEUS MINERAL GRAINS, G. J. Flynn¹ and S. R. Sutton², (1) Dept. of Physics, SUNY-Plattsburgh, Plattsburgh, NY 12901, (2) Dept. of Applied Science, Brookhaven National Laboratory, Upton, NY 11973.

Trace element abundances and abundance patterns in meteorites have proven to be diagnostic indicators of fractionation in the solar nebula (1) or on meteorite parent bodies (2), cosmothermometers indicating nebula temperature at formation of the meteorites (3), internal thermometers indicating the maximum reheating experienced since formation (4), and a means of defining genetically related groups of meteorites (5). If, as expected, comets are more primitive samples of the solar nebula than the meteorites, then trace element abundances in the comet nucleus samples should be better indicators of solar nebula conditions than the patterns in the meteorite samples.

EXPECTED PROPERTIES: Some micrometeorites collected from the earth's stratosphere after atmospheric deceleration are likely to be samples of comets (6). These 5 to 50 μm micrometeorites are generally aggregates of mineral grains, predominantly olivine and pyroxene, typically smaller than 1 μm . Major element analyses by analytical Transmission Electron Microscopy (TEM) show varying major element compositions for nearby grains of the same mineral (7). Bulk chemical analyses with sampling volumes of order 1 μm^3 show wide variations in major element compositions at adjacent spots on the same particle (8). If the elemental heterogeneity of the cosmic dust particles is indicative of the variation in comet nucleus material, then both major and trace element analyses on micron and sub-micron mineral grain samples will be required for maximum information extraction. Analytical TEM will permit such analyses for major elements.

PRESENT/FUTURE SXRF TRACE ELEMENT CAPABILITIES: Trace element analyses have been performed on bulk cosmic dust particles by Proton Induced X-Ray Emission (PIXE) (9) and Synchrotron X-Ray Fluorescence (SXRF) (10). When present at or near chondritic abundances the trace elements K, Ti, Cr, Mn, Cu, Zn, Ga, Ge, Se, and Br are presently detectable by SXRF in particles of 20 μm diameter. A SXRF spectrum of a chondritic micrometeorite is shown in Figure 1. Details of this analysis are described by Sutton and Flynn (10).

Improvements to the SXRF analysis facility at the National Synchrotron Light Source presently underway should increase the range of detectable elements and permit the analysis of smaller samples. In addition the Advanced Photon Source will be commissioned at Argonne National Laboratory in 1995. This 7 to 8 GeV positron storage ring, specifically designed for high-energy undulator and wiggler insertion devices, will be an ideal source for an X-ray microprobe with one micron spatial resolution and better than 100 ppb elemental sensitivity for

most elements. Thus trace element analysis of individual micron-sized grains should be possible by the time of the comet nucleus sample return mission.

SAMPLE REQUIREMENTS: Sample collection, delivery, and curation must be accomplished in a manner to avoid contamination with even trace amounts of the elements to be analyzed. The present SXRF sensitivity for micrometeorite analysis is of order 10^{13} atoms (about 0.1 pg) (10). Improvements in sensitivity will require sample contamination substantially below this level. Sample collection and handling equipment should be constructed from materials selected for ultra-high purity.

REFERENCES:

- 1.) Larimer, J.W. and Anders, E. (1967) Geochim. Cosmochim. Acta, 31, 1239-1270.
- 2.) Schnetzer, C.C. and Philpotts, J.A. (1969) In Meteorite Research (ed. P. Millman) Reidel, Dordrecht, 206-216.
- 3.) Keays, R.R. et al. (1971) Geochim. Cosmochim. Acta, 35, 337-363.
- 4.) Ikramuddin, M. (1977) Geochim. Cosmochim. Acta, 431, 1247-1256.
- 5.) Schaudy, R. (1969) Icarus, 17, 174-192.
- 6.) Brownlee, D.E. (1985) Ann. Rev. Earth Planet. Sci., 147-173.
- 7.) Fraundorf, P. (1981) Geochim. Cosmochim. Acta, 45, 915-943.
- 8.) Blanford, et al. (1988) Meteoritics, 23, #2, 113-122.
- 9.) van der Stapp, C.C.A.H. (1986) LPSC XVII, 1013-1014.
- 10.) Sutton, S.R. and Flynn, G.J. (1988) Proc. 18th Lunar Planet. Sci. Conf., 607-614.

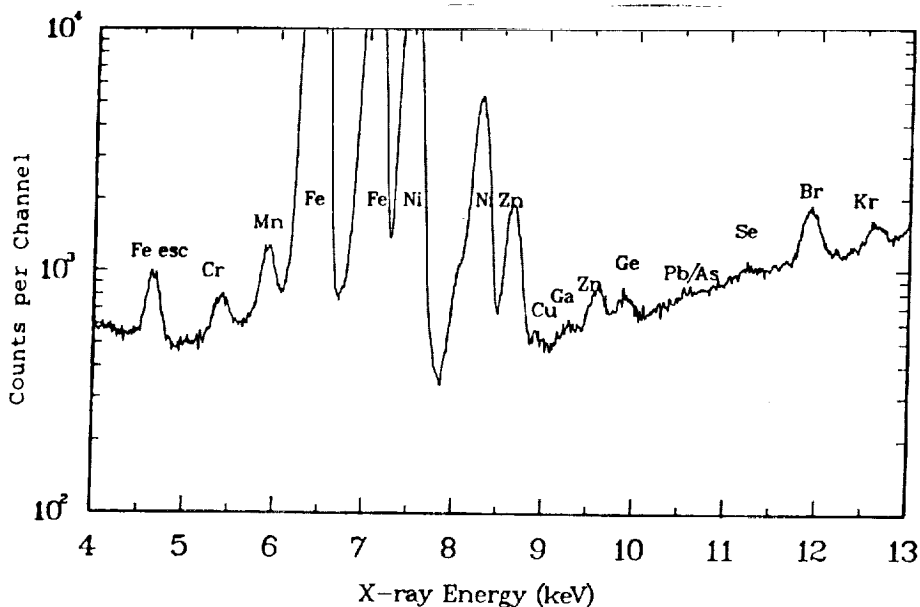

Figure 1. Synchrotron X-ray Fluorescence spectrum of micrometeorite U2022-G1, about 25 μm in diameter

FROM INTERSTELLAR DUST TO COMETS

J.M. Greenberg, Laboratory Astrophysics, Leiden, The Netherlands.

The bulk and microstructure of comet nuclei are derived from the morphological structure and chemical composition of submicron sized interstellar dust grains which have undergone cold aggregation in the pre-solar nebula (Greenberg 1982a, 1986a) because the volatile molecule S_2 may be traced back to the photochemical evolution of the interstellar dust (Grim and Greenberg, 1987) and because the CH_4/H_2O ratio is inconsistent with comet condensation of solar system volatiles (Larson et al. 1988).

The evolutionary picture of dust which is emerging is a cyclic one in which the particles, before being destroyed or going into solar system bodies, find themselves during their 5 billion year lifetime alternately in diffuse clouds and in molecular clouds (Greenberg, 1982b, Greenberg, 1986, Schutte, 1988). A small silicate core captured within a molecular cloud accretes various ices and gradually builds up an inner mantle of organic refractory material which has been produced by photoprocessing of the volatile ices. Because of the cyclic evolution the organic refractory mantle on a grain is not a homogeneous substance but rather layered like the rings of a tree trunk in which the innermost layers have been the most irradiated and the outermost layer in the most recent molecular cloud phase is first generation organic refractory which is surrounded finally by lightly photoprocessed ices of which H_2O is the dominant component. Since further photoprocessing of organics leads to a greater and greater depletion of O, N, and H, the innermost layers are the most "carbonized" and the most non-volatile (See Fig. 2 insert).

Clumps of grains form, and then clumps of clumps, and so on, until finally we reach the size of the comet nucleus. Comparing such interstellar dust aggregates with meteors leads to a packing factor of 0.2; (See Fig. 2a).



Fig. 2a: A piece of a fluffy comet: Model of an aggregate of 100 average interstellar dust particles with a packing factor of about 0.2 (80% empty space), a mean mass density of 0.28 gm cm^{-3} , and an aggregate diameter of $5 \text{ }\mu\text{m}$.

Fig. 2b: A highly porous chondritic IDP. Note that the bird's nest particle (Fig. 2a), the IDP (Fig. 2b) and average interstellar core-particle (Fig. 2b insert) are equally scaled to $1 \text{ }\mu\text{m}$.

ORIGINAL PAGE
BLACK AND WHITE PHOTOGRAPH

Kissel and Krueger (1987) have derived a comet dust ratio of organics to silicate mass of $m_{OR}/m_{Si1} = 1:2$ which, not surprisingly, is less than that in the interstellar dust because of the expected evaporation of the less refractory organics from the comet dust at solar system temperatures.

The 3.4 μm and 10 μm excess emissions in comet dust provide evidence not only for the basic chemical ingredients - as given in the mass spectra - but also for the morphological structure (Greenberg, Zhao and Hage, 1989). It turns out that pure silicates no matter how small do not achieve high enough temperatures to produce the observed 10 μm emission. Absorbing organic refractory mantles - such as those on interstellar silicate cores - are absolutely required to raise the compound grain temperatures high enough to make the 10 μm peak observable. Furthermore, the temperature constraint leads to a most probable silicate core radius - 0.05 μm and a mantle thickness ≥ 0.02 μm . i.e. an organic to silicate mass ratio $m_{OR}/m_{Si1} = 0.9$ which, within the uncertainties, is like that deduced from comet dust mass spectra. It is only by considering these 10^{-13} g particles to be in fluffy aggregates that the integrated fluxes come into reasonable resemblance to the particle impact detector data (McDonnell et al., 1987).

Interplanetary dust particles which are within 1 AU scatter visible light much more effectively than those which are beyond 1 AU. While those which are farther out are more effective emitters of infrared radiation. The radial decrease of the albedo of the zodiacal light particles could be produced by a decrease in material density, just as the albedo of cometary dust is decreased because of its fluffiness. The interplanetary particle probe results of Pioneer 10/11 were also interpreted in terms of a radial decrease of particle density (Fechtig, 1984). Additional indications for the cometary to interplanetary dust evolution may be seen in the lower density of meteors whose aphelion distances are beyond 5.4 AU as compared with those which spend more time closer to the sun (Verniani, 1973).

Although the mean density of the chondritic porous IDP's is low it is much higher than the initial cometary dust. What we see in Fig. 2b is an aggregate of more or less spherical particles of about 0.1 μ diameter whose infrared signature is that of silicates. When the interstellar dust is scaled like the IDP we see how its silicate core segments - which are hidden in the bird's nest model (Fig. 2a) - are like the silicates in the IDP. While the organic mantles are not "seen" in the IDP electron micrographs they become immediately apparent with Raman spectroscopy (Wopenka, 1988). It appears that every silicate particle in a porous IDP is covered by some organic mantle.

References

- Fechtig, H., 1984, Adv. Sp. Res. Vol. 4 no. 9, 5-11.
 Greenberg, J.M. 1982a, in Comets, ed. Wilkening, L.L. University of Arizona Press, 131-163.
 Greenberg, J.M. 1982b, in Submillimetre Wave Astronomy, eds. Phillips, D. and Beckman, J.E. Cambridge University Press, 261-306.
 Greenberg, J.M. 1986a, in: Asteroids, Comets and Meteors II, Uppsala University Press, 221-223.
 Greenberg, J.M. 1986b, in Light on Dark Matter ed. F P. Israel, (Reidel), 177-188.
 Greenberg, J.M., Zhao, Nansheng, Hage, J.I., 1988, Sp. Science Rev. in press.
 Grim, R.J.A. and Greenberg, J.M. 1987, Astr. Astrophys. 181, 155-168.
 Kissel J. and Krueger, F.R. 1987, Nature 326, 755-760.
 Larson, H.P. et al., 1988, Astrophys. J. in press.
 McDonnell, J.A.M. et al, 1987 Astron. Astrophys. 187, 719-741.
 Schutte, W. 1988, Ph.D. Thesis, 1-295.
 Verniani, F., 1973, J. Geophys. Res. 78, 8429-8462.
 Wopenka, B. 1988, Earth and Planet Sci. Lett. 88, 221.

MODIFICATIONS OF COMET MATERIALS BY THE SUBLIMATION PROCESS: RESULTS FROM SIMULATION EXPERIMENTS; E. Grün* and KOSI-team†, *Heidelberg, FRG

An active comet like comet Halley loses by sublimation a surface layer of the order of 1 m thickness per perihelion passage. In situ measurements (1) showed that water ice is the main constituent which contributes to the gas emission although even more volatile species (CO , NH_3 , CH_4 , CO_2 etc.) have been identified. Dust particles which were embedded in the ices are carried by the sublimating gases. Measurements of the chemical composition of cometary grains indicate that they are composed of silicates of approximate chondritic composition (2) and refractory carbonaceous material (3).

In the past there have been several attempts to experimentally study the sublimation process of mixtures of ices, minerals and carbonaceous compounds. Extensive work was carried out by Soviet groups in Dushanbe and Leningrad, who heated up ice samples electrically or irradiated them with light sources inside a cold chamber (4,5). Among the interesting findings was the formation and ablation of dust mantles during the sublimation process. In another approach (6,7), silicate minerals and organic compounds covered with water ice were exposed in a vacuum chamber. After sublimation of the water ice highly porous filamentary sublimate residues were found for some classes of phyllosilicate minerals or in cases when organic compounds (tar) were present.

The approach by the KOSI-team (8-10) focuses on the investigation of cometary processes at relevant scales. The scale of the simulation experiments is determined by the scale for the heat transport into the interior (diurnal thermal skin depth) and the scale of the gas interaction (mean free path length) above the surface which are both of the order of 10 cm. Comet simulation experiments are performed in the big Space Simulator of DFVLR, Cologne, which allows the study of samples of up to one meter dimensions.

Initial experiments were performed with porous water ice-mineral mixtures of 0.4 g/cm^3 bulk density which were irradiated at about 1 solar constant intensity for several hours. Representative temperature profiles taken at different times are displayed in Fig. 1. The temperature near the upper surface of the ice reached $> 200 \text{ K}$ at which significant sublimation occurred. With time the temperature profiles became flat near the surface. The layer of low temperature gradient was observed to grow in thickness during the course of the experiment. At the end of irradiation the investigation of the sample showed three distinct layers: A mantle of mineral dust of 5 to 10 mm thickness covered a several cm thick shell of hard but porous ice and dust. The layer below this shell was obviously in its original unconsolidated state.

† The KOSI-team is a consortium of scientific groups which are represented by: A. Bar-Nun, Tel Aviv University, Tel Aviv, Israel; E. Grün, P. Lämmerzahl, Max-Planck-Institut für Kernphysik, Heidelberg, FRG; J. Klinger, Lab. de Glaciologie et Geophysique de l'Environnement, Saint-Martin-d'Hères, France; H. Kochan, Institut für Raumsimulation, DFVLR, Köln-Porz, FRG; H.U. Keller, Max-Planck-Institut für Aeronomie, Katlenburg-Lindau, FRG; G. Neukum, Institut für Optoelektronik, DFVLR, Oberpfaffenhofen, FRG; K. Roessler, Institut für Chemie I, KFA, Jülich, FRG; D. Stöffler, T. Spohn, Institut für Planetologie, Münster, FRG; K. Thiel, Abt. Nuklearchemie, Universität, Köln, FRG.

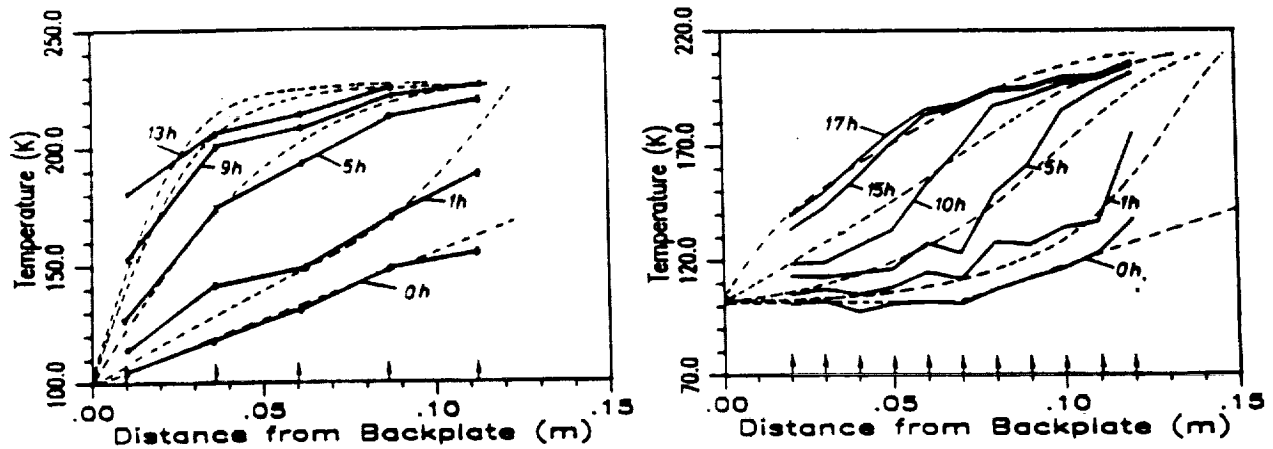

Fig. 1: Temperature profiles recorded during two simulation experiments (flat lines) and calculated from a thermal model (broken lines) at various times after the start of irradiation (10).

Both the temperature profile and the metamorphosis of the ice can be explained if we postulate that heat is advected towards the interior rather than conducted. The porosity of the sample allowed for water vapor to flow inwards driven by the difference in vapor pressure between the sublimating surface layer of ice and the cold interior. Model calculations (10) suggest that the vapor flow carried heat at a rate of about 60% of the heat input at the top surface of the ice. Recondensation of the vapor onto the original fluffy ice formed the hard icy shell.

Comet simulation experiments show that significant modifications of cometary materials occur due to sublimation process in near surface layers which have to be taken into account in order to derive the original state of this material.

References

- (1) Krankowsky D and Eberhardt P (1988) in Comet Halley 1986. World-Wide Investigations, Results and Interpretations, Ellis-Horwood Limited, Chichester, in press.
- (2) Jessberger E K, Christoforidis A and Kissel J (1988) Nature 332, p 691-695.
- (3) Kissel J and Krueger F R (1987) Nature 326, p 755-760.
- (4) Kajmakov E A and Sharkov V I (1972) in The Motion, Evolution of Orbits, and Origin of Comets (Chebotarev et al., eds), Reidel Publ. Comp., Dordrecht, p 308-314.
- (5) Ibadinov K I (1988) Adv. Space Res., in press.
- (6) Saunders R S, Fanale F P, Parker T J, Stephens I B and Sutton S (1986) Icarus 66, p 94-104.
- (7) Storrs A D, Fanale F P, Saunders R S and Stephens J B (1988) Icarus, in press.
- (8) Kochan H, Benkhoff J, Bischoff A, Fechtig H, Feuerbacher B, Grün E, Joo F, Klinger J, Kohl H, Krankowsky D, Roessler K, Seboldt W, Thiel K, Schwehm G and Weishaupt U (1988) Proc. 19th Lunar Planet. Sci. Conf., in press.
- (9) Klinger J, Benkhoff J, Espinasse S, Grün E, Ip W, Joo F, Keller H U, Kochan H, Kohl H, Roessler K, Seboldt W, Spohn T and Thiel K (1988) Proc. 19th Lunar Planet. Sci. Conf., in press.
- (10) Spohn T, Benkhoff J, Klinger J, Grün E and Kochan H (1988) Adv. Space Res., in press.

COMMENTS ON COMET SHAPES AND AGGREGATION PROCESSES

William K. Hartmann, Planetary Science Institute, Tucson AZ 85719

An important question for a comet mission is whether comet nuclei preserve information clarifying aggregation processes of planetary matter. Planets are too big to do so, and many (most) asteroids in the main asteroid belt have probably undergone enough metamorphism and/or collisional evolution to alter original aggregate textures resulting from low-velocity accretion processes, either on a micro- or macro-scale.

A common unexamined paradigm is that comets were thrown into the "deep freeze" of the Oort cloud during planet growth, and thus preserve "primitive" properties that can be found in no other solar system bodies. This common view may turn out to be naive. Comets could not be ejected until giant planets had grown, and the growth processes pumped up approach velocities of planetesimals. The whole accretion environment was one of collision, and by the time comet nuclei were ejected, they may have undergone collisional evolution, both in the original low-velocity accretion regime and in a later higher-velocity regime, perhaps inducing some fragmentation. Thus, while comets undoubtedly had less total collisional evolution than belt asteroids, the total collisional and velocity history is an unresolved problem.

The granularity of texture, at micro- to macro-scales, is an important indicator of this history, and can be studied by spacecraft. We anticipate that the aggregation phase occurred at very low relative velocities. The initial texture of the comet nuclei aggregates may have been one of fluff-balls of ice/soil crystals and grains at a micro scale. Sufficiently high resolution view might reveal whether such texture is present.

Another unexamined paradigm is that planetesimals grew out of innumerable small grains -- rather like building a 10-km body out of sand grains or peas. This has led to an almost unconscious supposition that primordial planetesimals (primitive comet nuclei?) were relatively spheroidal, and that the irregular shapes found among asteroids are due to fragmentation events, which produce splinter-like fragments. According to that view, unaltered primitive comet material may consist of innumerable small, highly-compacted grains (< meter-scale), but no larger sub-units (> km-scale), and unfragmented asteroids would be relatively spheroidal.

That view is being challenged by unexpected new observational evidence. Hartmann et al. (1987, 1988) and French (1987) have found that Trojan asteroids, as a group, display a higher fraction of highly-elongated objects than the belt. More recently evidence has accumulated that comet nuclei, as a group, also display highly-elongated shapes at macro-scale. This evidence comes from the several comets whose nuclear lightcurves or shapes have been well studied. Figure 1 shows this evidence.

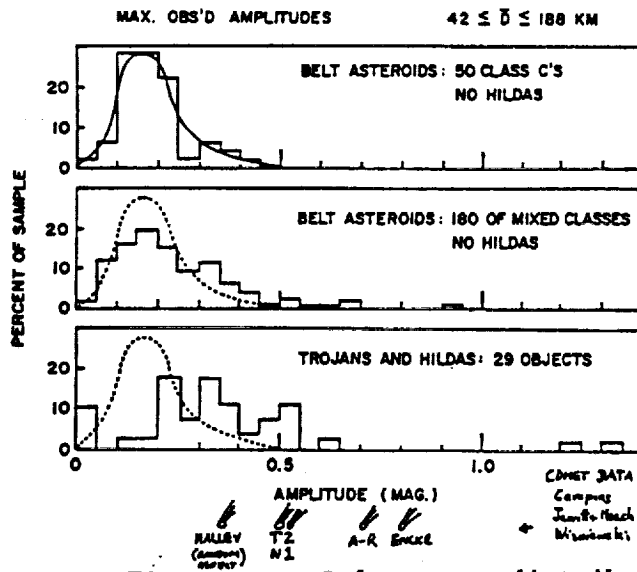

Figure 1. Histograms of frequency distribution of amplitudes of samples of main-belt asteroids (top and middle) and Trojan asteroids (bottom). Bell curve repeats a rough fit to the top distribution, for reference. Trojans have a tail of highly irregular shapes. At bottom are data for several comets, indicating that they, too, have irregular shapes.

Intriguingly, Trojans and comet nuclei share other properties. Both groups have extremely low albedos and reddish-to neutral-black colors typical of asteroids of spectral class D, P, and C. Both groups may have had relatively low collision frequencies.

An important problem to resolve with spacecraft imaging is whether these elongated shapes are primordial, or due to evolution of the objects. Two hypotheses that might be tested by a combination of global-scale and close-up imaging from various directions are:

(1) The irregular shapes are primordial and related to the fact that these bodies have had lower collision frequencies than belt asteroids. This could arise if the planetesimal population produced moderate size bodies (such as km-scale Goldreich-Ward planetesimals), which then "fell together," accreting at such low velocities that they produced "compound asteroids" in which original lumpy shapes have been preserved. Donn has shown growth of such irregular shaped bodies in a theoretical modelling program. In this case, imaging might show residual shapes of the initial, aggregated, bodies, stuck together like snowballs in a snowman, with possible smoothing by subsequent collisions.

(2) The irregular shapes may be due to volatile loss. This seems possible since they appear in volatile-rich bodies, and not so frequently in main-belt asteroids. Colwell and Jakosky (1987, Icarus) have described increase in topographic extremes due to sublimation and insolation considerations. Comets might evolve toward more elongated shapes. This could explain observed spontaneous splitting as an end result. Spacecraft observation of jetting and fissure evolution might clarify this process.

COSMOGENIC NUCLIDES IN COMETARY MATERIALS: IMPLICATIONS FOR RATE OF MASS LOSS AND EXPOSURE HISTORY; G.F. Herzog¹, P.A.J. Englert², and R.C. Reedy³, 1) Dept. Chem. Rutgers Univ., New Brunswick, NJ 08903 2) Dept. Chem. San Jose State Univ., San Jose, CA 95192 3) Los Alamos Natl. Lab., Los Alamos, NM 87545

As planned the Rosetta mission will return to earth with a 10-kg core and a 1-kg surface sample from a comet [1]. The selection of a comet with low current activity will maximize the chance of obtaining material altered as little as possible. Current temperature and level of activity, however, may not reliably indicate previous values. Fortunately, from measurements of the cosmogenic nuclide contents of cometary material, one may estimate a rate of mass loss in the past and, as a bonus, learn something about the exposure history of the comet. Perhaps the simplest way to estimate the rate of mass loss is to compare the total inventories of several long-lived cosmogenic radionuclides (Table 1) with the values expected on the basis of model calculations. Although model calculations have become steadily more reliable [e.g., 2], application to bodies with the composition of comets [3] will require some extension beyond the normal range of use. In particular, the influence of light elements on the secondary particle cascade will need study, in part through laboratory irradiations of volatile-rich materials. In the analysis of cometary data, it would be valuable to test calculations against measurements of *short-lived* isotopes.

Importance of short-lived isotopes - The inventories of short-lived isotopes at depths greater than a few centimeters should be relatively insensitive to mass wastage for the anticipated [1] erosion rates. Moreover, because the gradient of galactic cosmic rays in the inner solar system is small, $\sim 2\%/A.U.$ [4], the recent production rates of these (and longer-lived) radioisotopes do not depend sensitively on orbital parameters in the ranges considered. For these reasons, and just as in the lunar case [5], the short-lived radionuclides provide either a corroboration of the calculations or the data needed for fine tuning them.

Measurement of short-lived isotopes - During the return trip of ~ 3 y, isotopes with half-lives less than 1 y (e.g., ⁵⁴Mn and ⁵⁷Co) will have decayed away. Isotopes with somewhat longer half-lives would survive the trip and could be conveniently and non-destructively measured in the laboratory. However, cosmic ray bombardment *en route* would have altered their concentrations. Either of two approaches could prevent the otherwise irretrievable loss of information about these important isotopes. 1) *In situ* measurements. By mounting a detector in the reconnaissance craft it might be possible to detect and analyze γ -radiation emitted from the comet's surface. Backgrounds from the spacecraft and the γ -detector itself would make the detection of both prompt [6] and decay gammas from the comet difficult. Alternatively, a detector could be placed in a core hole [7,8]. The location would largely protect the detector and surrounding material from direct exposure to cosmic rays but signals from prompt γ 's may still overwhelm those from decay. 2) Spacecraft measurements. To measure the effects of cosmic-ray bombardments on the material during transport back to earth, one might include a γ -detector and/or certain passive devices in the spacecraft. Englert [8] discusses shielding arrangements. If these measurements are to be undertaken, detailed feasibility studies will be needed soon.

Long-lived isotopes - Table 1. Data for selected, long-lived cosmogenic radionuclides [9].

Isotope	³² Si	¹⁴ C	⁴¹ Ca	³⁶ Cl	²⁶ Al	¹⁰ Be	⁵³ Mn
Half-life	150 \pm 25y	5,730y	0.1 My	0.3 My	0.7 My	1.5 My	3.7 My
Targets	S,Ca,Fe	O,N?	Ca,Fe	K,Cl?,Fe,Ca	Al,Si	C,O,Mg,Si	Fe,Ni
Det. Lim./10 ⁶ at		0.2	1	0.5	0.4	0.2	200

Figure 1 shows the fractional inventories of various radioisotopes that a comet would retain assuming the rates of mass loss given by [1]. These illustrative calculations assume negligible erosion rates in the distant past, constant erosion rates for the last 1000 y, and a constant cosmic ray flux throughout. We adopted production rates of the form $P = P_0 e^{-\rho d}$ where $d = d_0$ initially and $d = d_0 - \epsilon t$ during the period of appreciable mass loss. In this simplified model, the longer-lived cosmogenic radionuclides are diagnostic for the anticipated range of

erosion rates. Current techniques would make it possible to profile a large suite of long-lived cosmogenic radionuclides along the entire core with just 1-2 g of material. In the past, when the comet may have had considerably larger aphelia, production rates may have been higher by a factor of about 4 [10]. Figure 2 shows how the isotope inventories would increase with a higher, ancient flux which is taken as a constant, L , times the current flux. We have assumed the two-stage model described above with $T_2 = 1000$ y and an intermediate rate of mass loss of $0.2 \text{ g/cm}^2\text{-y}$. If we assume a non-increasing flux of galactic cosmic rays throughout the orbital history of the comet then cosmogenic radionuclide data will allow us to place a lower limit on the average rate of mass loss.

Information concerning certain short- and long-lived isotopes can be paired advantageously. For example the ratio $^7\text{Be}/^{10}\text{Be}$ should be insensitive to chemical fractionation that may occur during volatilization processes and to the details of the secondary spectrum of cosmic-ray particles. On the other hand, in the simplest picture, significant mass loss on a time scale of millions of years or less will raise the $^7\text{Be}/^{10}\text{Be}$ ratio. Taken in conjunction with an estimate of the rate of mass loss, the $^{22}\text{Na}/^{22}\text{Ne}$ ratio provides information about the time the sample lay within a few meters of the surface.

The behavior of the cosmogenic radionuclides as the comet loses mass could well hold some surprises. Major production of ^7Be , ^{10}Be , and ^{14}C will occur in $\text{H}_2\text{O}(\text{s})$ and $\text{CO}_2(\text{s})$. The fate of the ^{14}C is uncertain. Lal et al. [11] have argued that nascent ^{14}C in ice quickly forms CO . If so, it would be lost with the gas but otherwise, perhaps not. Similarly, some H_2O - or CO_2 -derived ^xBeO , which is nonvolatile, might conceivably remain behind when ices vaporized. If the isotopes are retained during the loss of ices, the inventories of ^{10}Be and/or ^{14}C would exceed expected values. Excesses in the amounts of these isotopes unaccompanied by excesses in long-lived isotopes not made from C, N, or O would provide a novel marker of cometary surface processes. Finally, we note that ionizing radiation may initiate the formation of polymers [12]. The determination of the ^{14}C content (and perhaps the ^{10}Be content) of polymeric material would therefore be of interest as a potential measure of its age. More generally, the cosmogenic nuclide contents will lead to an estimate of the total dose of ionizing radiation and this quantity may be useful in the interpretation of the properties of the cometary surface.

Fig. 1

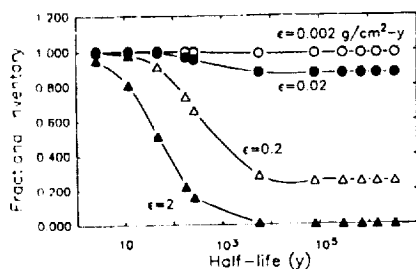
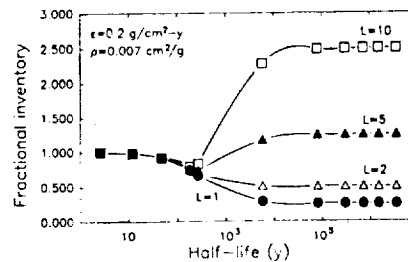

Fig. 2



- References:** 1. T.J. Ahrens et al. (1987) *Rept. SCI(83)3, Space Sci. Dept., ESA*, 1-64. 2. R.C. Reedy (1985) *Proc. 15th Lunar Planet. Sci. Conf., J. Geophys. Res.* 90, C722-C728. 3. A.H. Delsemme (1988) *Phil. Trans. R. Soc. Lond.* A325, 509-523. 4. J.A. Van Allen and B.A. Randall (1985) *J. Geophys. Res.* 90, 1399-1412. 5. R.C. Reedy and J.R. Arnold (1972) *J. Geophys. Res.* 77, 537-555. 6. A.E. Metzger et al. (1986) *Proc. 16th Lunar Planet. Sci. Conf., J. Geophys. Res.* 91, D495-D504; J. Bruckner et al. (1987) *Proc. 17th Lunar Planet. Sci. Conf., J. Geophys. Res.* 92, E603-E616. 7. L.G. Evans et al. (1986) *Proc. 16th Lunar Planet. Sci. Conf., J. Geophys. Res.* 91, D525-D532. 8. P.A.J. Englert (1988) *LPI Tech. Rep.* 88-07, 75-6. 9. Adapted from D. Elmore and F.M. Phillips (1987) *Science* 236, 543-550. 10. G.M. Raisbeck et al. (1985) *Meteoritics* 20, 734-735; Reedy (1987) *Proc. 17th Lunar Planet. Sci. Conf., J. Geophys. Res.* 92, E697-E702. 11. D. Lal et al. (1987) *J. Geophys. Res.* 92, 4947-4952. 12. W.F. Huebner (1987) *Science* 237, 628-630; D.L. Mitchell et al. (1987) *Science* 237, 626-628.

MORPHOLOGY AND COMPOSITIONAL DIFFERENTIATION OF THE SURFACE OF COMETS; W. F. Huebner and D. C. Boice, Southwest Research Institute, San Antonio, TX 78284

The remarkable spacecraft missions to Comet Halley gave us the first detailed view of a comet nucleus. What was suspected before, that the nucleus surface was heterogeneous, was spectacularly confirmed. The Halley Multicolour Camera aboard Giotto recorded jet-like dust features emanating from active regions covering approximately 15 percent of the surface that were responsible for emitting most of the dust and gas. An intensity gradient across the nucleus originating at the active areas and falling off to the darker, inactive region on the night side is caused by small particles that are more easily entrained by surface winds than larger particles that tend to remain in the "jets". Data from the PIA (Giotto) and PUMA (Vega 1,2) instruments indicate that the smallest dust particles are enriched with organics (CHON particles). Some of this fine dust gravitationally settles creating a thin surface layer rich in organics. Particularly strong dust "jets" may cause wind-blown surface structures over inactive areas, such as, leeward dust accumulation behind hills. At close heliocentric distances the fine dust may be sintered on the surface.

The Giotto images revealed crater-like features seen in the inactive area which may be evidence of extinct source regions. Similar regions may develop around the active areas creating crater-like rims. These rims are built up by the largest particles that can be lifted by the escaping gas. The lack of lift caused by the divergence of the gas flow near the boundary of the active region results in their accumulation in the rim. Because of the rotation of the nucleus, deposits of these larger particles will be preferentially on the side opposed to the rotation (the morning side). These larger particles which may be approximately one meter in size contain trapped frozen gases and more silicates compared to the fine dust.

Including the active areas which are rich in volatiles, we are lead to a picture of a comet nucleus surface with structural and compositional differentiation with at least three distinct regions: 1) inactive regions covered by a thin layer of fine dust enriched in organics that may be sintered, 2) crater-like rims made up of larger particles containing trapped frozen gases and silicates, and 3) the active regions which are rich in frozen gases and dust. We suggest that the Comet Nucleus Sample Return mission plan to sample at least these three compositionally distinct regions.

ROLE OF DUST TO GAS PRODUCTION RATE RATIO
IN COMETARY PHYSICS

S. Ibadov

Institute of Astrophysics, Dushanbe 734670, USSR

According to results of Earth based observations and in situ measurements cometary nuclei are intensive sources of both the gaseous and the dusty matter /see, e.g., 1-6/. Investigation of the interaction between gas-dust cometary atmospheres and dust grains of the Zodiacal dust cloud reveals the presence of two principally possible mechanisms: meteor-like and explosive-type ones.

The meteor-like mechanism is connected with bombardment of zodiacal dust particles by cometary molecules when the temperatures $T = 2000-3000$ K are developed. This mechanism can create over-saturated vapours of refractory elements (Fe, Si, C etc.) in cometary heads /7/.

The explosion-type mechanism is connected with high-velocity impacts between cometary and zodiacal dust particles resulting in the generation of high-temperature plasma ($T = 10^5-10^7$ K) and, hence, of X-ray radiation and multicharged ions, i.e. with the processes not yet realized in the laboratory conditions /8/.

The dust to gas production rate ratio, $\mu \equiv \dot{M}_d/\dot{M}_g$, determines the dominating interaction mechanism, namely if $\mu \geq 0.1$ explosion-type mechanism is the main one /9/.

Such important for cometary physics parameter as μ may directly be determined by analysing the returned comet nucleus samples. For this purpose the masses (or corresponding spectra) of gaseous and dusty matter ejected from the sample during a given time must be measured.

References

1. Whipple F.L. 1950 *Astrophys. J.* 111, 375-394.
2. Dobrovolsky O.V. 1966 *Comets*, Moscow, Nauka.
3. Wilkening L.L. (Ed.) 1982 *Comets*, Tucson, Arizona University Press.
4. Sagdeev R.Z. et al. 1986 *Nature* 321, 259-262.
5. Reinhard R. 1986 *Ibid*, 313-318.
6. Shulman L.M. 1987 *Nuclei of Comets*, Moscow, Nauka.
7. Dobrovolsky O.V. and Ibadov S. 1980 *Proc. Internat. Workshop Modern Observat. Techn. for Comets*, JPL Publ. 81-68, 39-41.
8. Ibadov S. 1986 *Proc. 20th ESLAB Symposium Exploration of Halley's Comet*, ESA SP-250, 377-378.
9. Ibadov S. 1987 *Proc. Internat. Symposium Diversity and Similarity of Comets*, ESA SP-278, 655-656.

RADIATION MODIFICATION OF COMETARY MATERIALS: LABORATORY
SIMULATIONS; R.E. Johnson, University of Virginia Charlottesville, VA 22901

Cosmic rays and solar photons can modify precometary materials, comet surfaces, and ejected cometary materials. This can be of importance for describing the primordial crust of a comet, the composition of the ejected dust, and the degradation of the dust in the solar environment. This paper will describe the laboratory results of interest to radiation modification of materials, the effects of radiation on cometary materials and the relevance of these materials for comet surface analysis.

SULFUR COMPOUNDS IN COMETS; S. Kim and M. A'Hearn (University of Maryland)

Cometary atmospheres exhibit abundant sulfur and sulfur compounds, which are absent in planetary atmospheres. Sulfur compounds were also detected in interstellar media, including SO, SO₂, CS, etc., but excluding S₂ which was identified only in IRAS-Araki-Alcock 1983d. The study of the origin and parent molecules of these compounds, therefore, may yield a clue to the question of the formation and evolution of comets, interstellar media, and planets.

Most models of comets suggest that SO and/or SO₂ should be abundant in the coma both because of reactions between the observed species S and OH and

because of irradiation of other sulfur compounds in icy grains prior to accretion. A tentative identification of SO has been proposed by Wallis and Krishna-Swamy (1). We have calculated synthetic spectra of SO and compared them with spectra of various comets taken with the International Ultraviolet Explorer. We find no evidence for the presence of SO and set upper limits on the relative production rate of SO in comets. (Fig. 1)

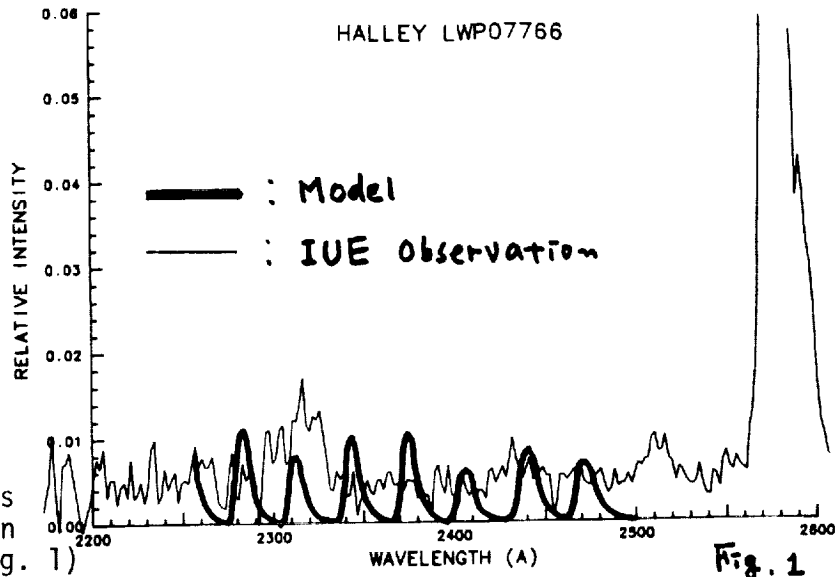

It has been difficult to explain the high resolution IUE spectra of the 0-0 band of CS at 2577 Å, because CS radicals are formed near the nucleus where collisions may affect the rotational structure of this band (2). Motivated by the incomplete analysis by Prisant and Jackson (2), we attempted to construct a band model which includes fluorescence processes initiated by solar ultraviolet radiation, and collisional excitation by electrons and neutrals. In Fig. 2, we present models of the 0-0 band, which give satisfactory fits to the high resolution IUE spectra of comets Halley and Wilson. We will discuss the collisional effects, and electron and neutral densities in the CS forming region.

We undertook fluorescence calculations to analyze the B-X system of S₂ which appeared in IUE and ground-based spectra of IRAS-Araki-Alcock 1983d. Single- and multiple-cycle fluorescence calculations indicate that fluorescent equilibrium accounts for the observed spectra despite the fact that the S₂ lifetime against solar ultraviolet radiation is relatively short. This analysis confirms unambiguously that emission peaks in the 3000 - 4000 Å spectral range of the ground-based data are due to the B-X bands of S₂ (Fig. 3).

We also present new evidence that at least one S_2 outburst before it was detected by A'Hearn, Feldman, and Schleicher (3). The time variation of S_2 outgassing rates and discussion on the correlation between solar wind flux and the S_2 outbursts will be presented.

REFERENCES

- (1) Wallis, M.K. and Krishna-Swamy, K.S. (1987) *Astron. & Astrophys.* v. 187, pp. 329-332
- (2) Prisant, M.G. and Jackson, W.M. (1987) *Astron. & Astrophys.* v. 187, pp. 487-496
- (3) A'Hearn, M.F., Feldman, P.D., Schleicher, D.G. (1983) *Astrophys. J.* v. 274, pp. L99-L103.

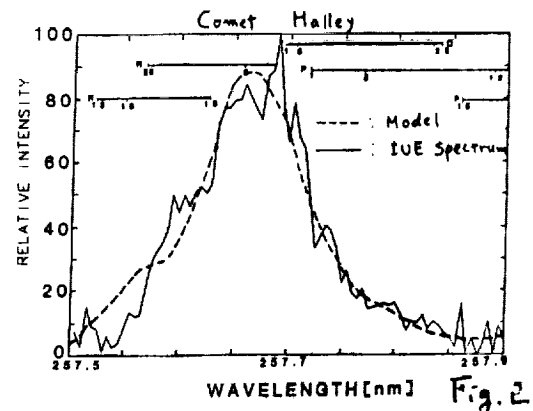
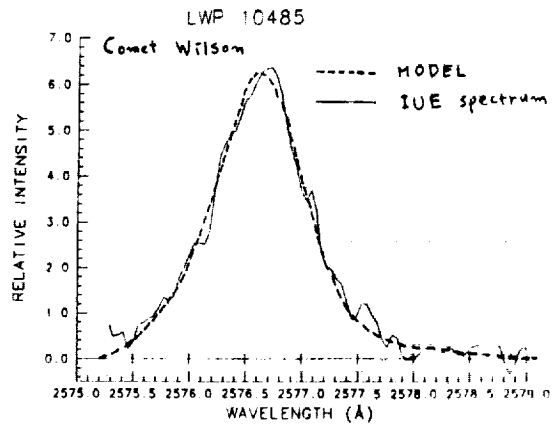

Fig. 2

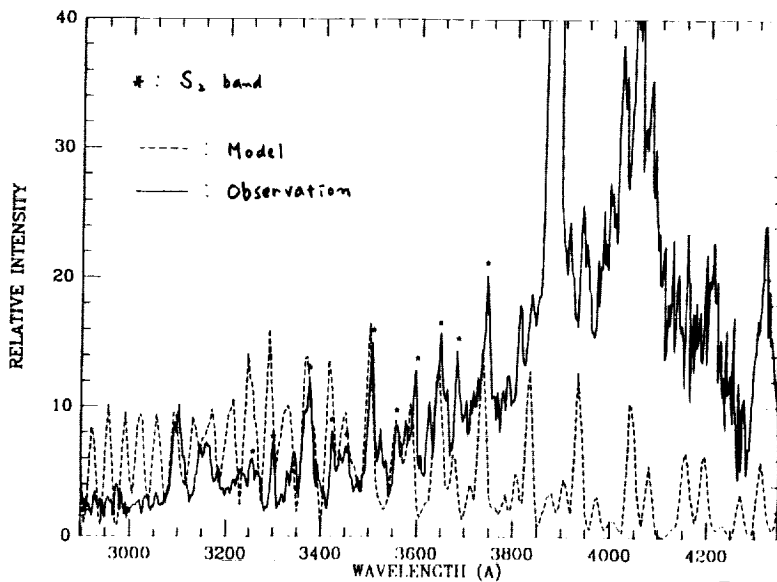

Fig. 3

Organic Chemistry of Cometary Dust as Derived From PUMA 1 Data

J. Kissel, MPI fuer Kernphysik, Postfach 103980, D-6900 Heidelberg 1
and F.R. Krueger, Ingenieurbuero Krueger, Messeler Str. 24,
D-6100 Darmstadt 12

Onboard the Halley Fly-By spacecrafts VEGA 1, VEGA 2, and GIOTTO were the dust impact mass spectrometers PUMA 1, PUMA 2, and PIA respectively. PUMA 1 was the most sensitive instrument among them. From its data the occurrence of masslines >60 Daltons could be shown to be statistically significant. An analysis of these masslines lead to a scenario, which could explain the masslines as fragment ions from larger molecules which characterize the chemical nature of cometary organic matter as:

- highly unsaturated hydrocarbons
- some of them containing oxygen,
- less containig nitrogen, and
- a few containing oxygen and nitrogen as heteroatoms.

From the properties of the spectrometer, also some physical parameters of the dust particles could be inferred, such as their density and structure.

IDENTIFICATION OF SOLAR NEBULA CONDENSATES IN INTERPLANETARY DUST PARTICLES AND UNEQUILIBRATED ORDINARY CHONDRITES.

W. Klöck¹, K.L. Thomas² and D.S. McKay¹, ¹ SN14, NASA/JSC, Houston, TX, 77058; ² Lockheed, 2400 Nasa Rd.1, Houston, TX, 77058

Orthopyroxene and olivine grains, low in FeO, but containing MnO contents up to 5 wt% were found in interplanetary dust particles (IDP) collected in the stratosphere (Fig.1). The majority of olivines and pyroxenes in meteorites contain less than 0.5 wt% MnO (Fig.2). Orthopyroxenes and olivines high in Mn and low in FeO have only been reported from a single coarse grained chondrule rim in the Allende meteorite (1) and from a Tieschitz matrix augite grain (2). The bulk MnO contents of the extraterrestrial dust particles with high MnO olivines and pyroxenes are close to CI chondrite abundances (3) except for 3 particles which are enriched in Manganese by factors of 2-6.

High MnO, low FeO olivines and orthopyroxenes were also found in the matrix of Semarkona, an unequilibrated ordinary chondrite (Fig.3). This may indicate a related origin for minerals in extraterrestrial dust particles and in the matrix of unequilibrated ordinary chondrites.

The origin of the observed Mg-silicates with high MnO contents, but having low iron contents, can be best understood by condensation processes from a gas of solar composition. Forsteritic (Fe-poor) olivine is the first major silicate phase to condense from a solar gas. Iron would condense as metal and react at rather low temperatures (500 K- 600 K) with forsteritic olivine to produce Fe-rich olivine. However, Mn, which is not stable as metal in the solar nebula would condense at around 1100 K as Mn_2SiO_4 in solid solution with forsterite (4,5). High MnO, low FeO olivines may have formed by condensation above 1000 K but failed to equilibrate with metallic iron at lower temperatures.

Low temperature metamorphic reactions may produce FeO- and MnO- rich olivines but are unable to explain the formation of FeO-poor MnO-rich olivines. The occurrence of solar nebula condensates in IDP's would be remarkable. Either the origin of IDP's is more closely related to chondritic meteorites than previously thought or comets, which are believed to be the parent bodies of chondritic porous IDP's (6,7,8,9), contain high temperature minerals, formed by condensation in the solar nebula.

References: (1) Rubin A.E. (1984) *Amer. Miner.* 69, 880-888. (2) Hutchinson R. (1987) *Min. Mag.* 51, 311-316. (3) Thomas K.L., Klöck W., Blanford G.E., McKay D.S. (1988) abstract 51th Met. Soc. Meeting. (4) Larimer J.W. (1967) *Geochim. Cosmochim. Acta* 31, 1215-1238. (5) Wai C.M., Wasson J.T. (1977) *Earth Planet. Sci. Lett.* 36, 1-13. (6) Anders E. (1986) *ESA Spec. Public.* 249, 31-39. (7) Bradley J.P. (1988) *Geochim. Cosmochim. Acta* 52, 889-900. (8) Brownlee D.E., Wheelock M.M., Temple S., Bradley J.P., Kissel J. (1987) abstract *Lunar Planet. Sci.* 18, 133-134. (9) Rietmeijer F.J.M., Mackinnon I.D.R. (1987) *ESA Spec. Public.* 278, 363-367.

W. Klöck, K.L. Thomas, D.S. McKay

FeO-AND MnO ABUNDANCES IN OLIVINES AND PYROXENES OF EXTRATERRESTRIAL DUST PARTICLES

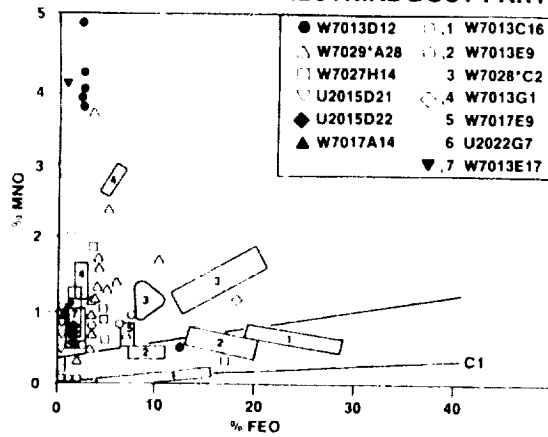

Fig. 1

FeO and MnO abundances in olivines and pyroxenes of extra terrestrial dust particles

FeO-AND MnO ABUNDANCES IN METEORITIC OLIVINES AND PYROXENES

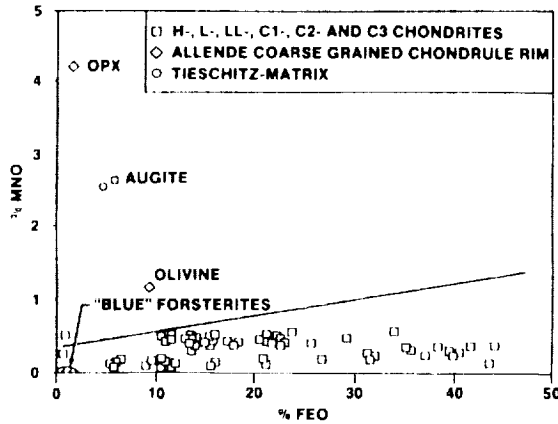

Fig. 2

FeO and MnO abundances in olivines and pyroxenes of various undifferentiated meteorites. MnO contents are always below 0.5 wt% and show no increase with increasing iron content.

COMPOSITION OF OLIVINES IN THE MATRIX OF SEMARKONA (LL3)

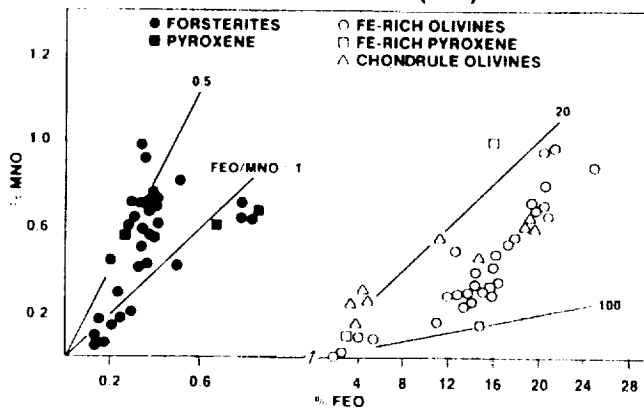

Fig. 3

Composition of olivine in the Semarkona matrix. Two olivine populations were found in the opaque matrix.
 1. Fe-rich olivines compositionally similar to chondrule olivines.
 2. Mg-rich olivines characterized by their Fe/Mn ratios of 0.5 - 1.0.

SPECTROPHOTOMETRIC OBSERVATIONS OF COMET

P/GIACOBINI-ZINNER; I. Konno, Max-Planck-Institut für Astrophysik, Garching, FRG; S. Wyckoff, and P.A. Wehinger, Arizona State University

Spectroscopic observations of comet P/Giacobini-Zinner were performed on 20 March, 20 and 21 June, 11 September, and 19 October 1985. The September observations were performed at perihelion, *exactly* at the time of the International Cometary Explorer (ICE) encounter with the comet. The March and June observations were obtained with an Intensified Image Dissector Scanner (IIDS) on the 2.1-meter Kitt Peak telescope and the September and the October observations were obtained with a Charge-Coupled Device (CCD) on the 4-meter Kitt Peak telescope.

In the spectrum obtained in March, only CN($\Delta v=0$) emission was marginally present with a strength $\sim 1\sigma$ above the noise level. Nucleus spectra obtained on June 20 and 11 September are shown in Figures 1 and 2. Neither Na nor C_2^+ was detected in the September spectrum. Therefore Na^+ and C_2^+ can be excluded from the candidates for the ions in the mass range 23 to 24 amu detected by the ICE ion composition experiment (Ogilvie et al. 1986).

The brightness profile of C_2 and the lifetime of the parent of C_2 , 1.1×10^5 s, indicate that C_2 molecules probably come from many different sources which may include C_2H_4 , C_2H_2 , and dust. From brightness profiles obtained from the September observations it was found that C_2 and NH_2 are depleted in Giacobini-Zinner by factors of ~ 10 and ~ 5 respectively compared with the normal comet (Sclischer et al. 1987). Detailed analyses of the brightness profiles of these species made using Monte Carlo techniques have been

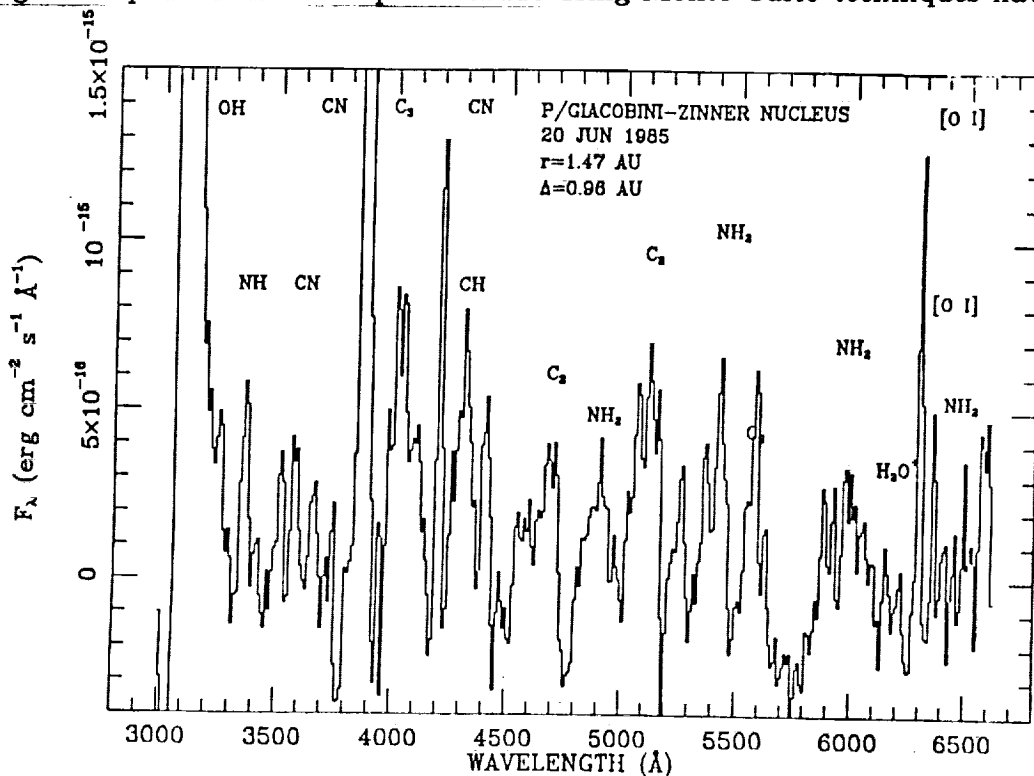

Fig. 1. Nucleus spectrum of comet Giacobini-Zinner on 20 June 1985.

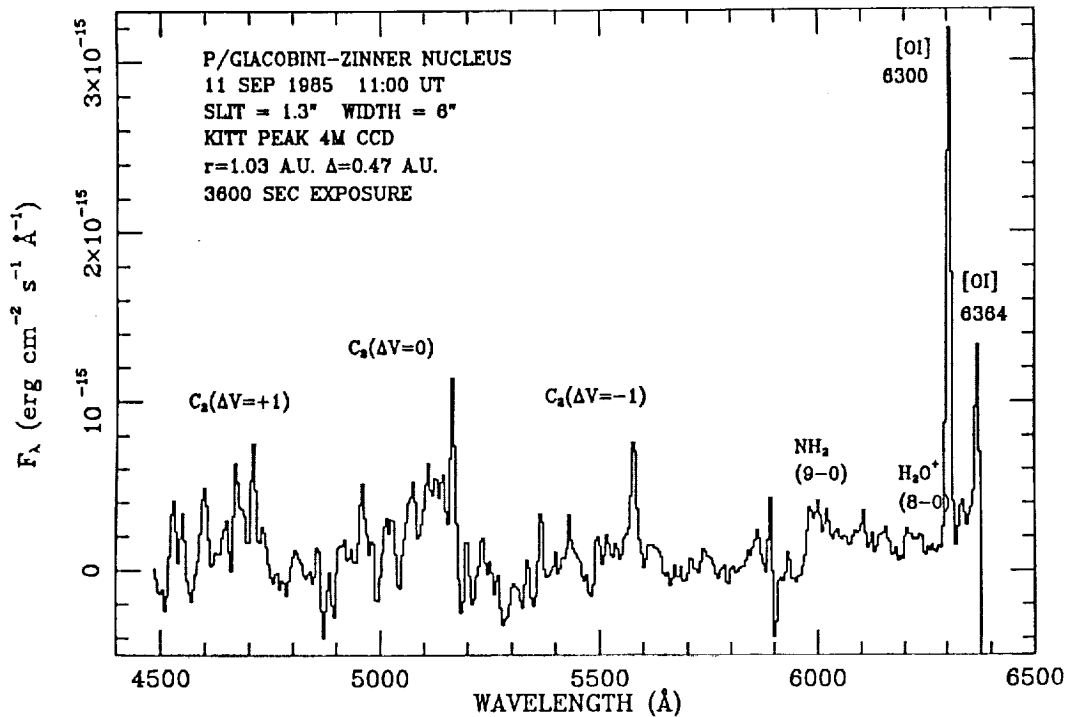

Fig. 2. Nucleus spectrum of comet Giacobini-Zinner on 11 September 1985.

discussed elsewhere (Konno 1987, Konno and Wyckoff, 1988). Observations in June indicate that C_3 and NH may also be depleted in Giacobini-Zinner by ~ 8 and ~ 5 times the normal value, respectively. The ratio of the production rates, $Q(NH_2) = Q(H_2O) = 2 \times 10^4$ indicate a very low NH_3/H_2O abundance ratio if NH_2 comes mostly from photodissociation of NH_3 .

The water production rates for the comet were found from the measurements of the $[O I] 6300 \text{ \AA}$ line: 1.7×10^{28} at $r = 1.47$ AU on 20 June, 1.7×10^{28} at $r = 1.46$ AU on 21 June, 2.4×10^{28} at $r = 1.03$ AU on 11 September, and 2.6×10^{28} at $r = 1.20$ AU on 19 October. The value on 11 September falls in the range $2 \times 10^{28} - 5 \times 10^{28}$ molecules s^{-1} indicated by IUE and the Pioneer Venus Orbiter (Stward et al. 1985). From $r = 1.47$ AU to $r = 1.03$ AU (perihelion) the production rate changes as $\sim r^{-1}$ but it does not fall off after perihelion from September to 19 October ($r = 1.20$ AU). This behavior may be due to heating of the outer layers of the nucleus at perihelion, so that the production rate probably did not change to the distance $r = 1.20$ AU.

References

- Konno, I., 1987, Ph.D. thesis, Arizona State University.
- Konno, I., Wyckoff, S., in Proceedings of COSPAR XXVII, to be published.
- Ogilvie, K.W., Coplan, M.A., Bochsler, P. Geiss, J., 1986, *Science*, **232**, 374.
- Schleicher, D.G., Millis, R.L., Birch, P.V., 1987, *Astron. Astrophys.*, **187**, 531.
- Stewart, A.I.F., Combi, M.R., Smyth, W.H., 1985, *Bull. Am. Astron. Soc.*, **17**, 686.

Composition of Dust from Comet P/Halley: The Mineral Fraction

Y. Langevin, Laboratoire Rene-Bernas du CSNSM, 91406 Orsay, France

The composition of dust from P/Halley has been investigated in situ during the VEGA 1, VEGA 2 and GIOTTO encounters by the PIA/PUMA impact mass spectrometers. More than 5000 meaningful spectra of individual dust particles were obtained, most of which in a compressed mode. The interpretation of these spectra in terms of elemental and mineralogical composition will be discussed. Accounting for these difficulties, the following conclusions can be derived for the mineral fraction of dust particles: i) the observed compositions are compatible with the full range of observed meteoritic minerals (in particular mafic silicates, plagioclases, sulfides, oxides); ii) Within each mineralogical class, the spread in composition appears much wider and more uniform than in meteorites. The low overall density and very large excess of light elements will be discussed by J. Kissel. These first direct results on cometary dust considerably strengthen the case for a comet sample return mission.

COMPUTER SIMULATION OF DUST GRAIN EVOLUTION

K. Liffman, NASA Ames Research Center, M.S. 245-3, Moffett Field, CA 94035

We present a status report on the latest results obtained from a Monte Carlo code that is being developed at NASA Ames. The goal of this program, is to derive from the observed and presumed properties of the Interstellar Medium (ISM) the following information:

- (1) The size spectrum of interstellar dust
- (2) The chemical structure of interstellar dust
- (3) Interstellar abundances
- & (4) The lifetime of a dust grain in the ISM.

Clearly a sample of a comet would allow us to compare theory with reality - at least for the first two of the four listed goals.

Presently our study is restricted to refractory interstellar material, i.e. the formation and destruction of ices are not included in the program. The program is embedded in an analytic solution for the bulk chemical evolution of a two-phase interstellar medium in which stars are born in molecular clouds, but new nucleosynthesis products and stellar return are entered into a complementary intercloud medium. The well-mixed matter of each interstellar phase is repeatedly cycled stochastically through the complementary phase and back. Refractory dust is created by thermal condensation as stellar matter flows away from sites of nucleosynthesis such as novae and supernovae and/or from the matter returned from evolved intermediate stars.

The history of each particle is traced by standard Monte Carlo techniques as it is sputtered and fragmented by supernova shock waves in the intercloud medium. It also accretes an amorphous mantle of gaseous refractory atoms when its local medium joins with the molecular cloud medium. Finally it encounters the possibility of astration (destruction by star formation) within the molecular clouds. This scenario is presented schematically in fig. 1 and actual data from a case run where the grains were allowed to fragment into one hundred pieces whenever there was a grain-grain collision are presented in fig. 2. It should be noted that in fig. 2 any grains smaller than 5 Å are considered to be gas molecules.

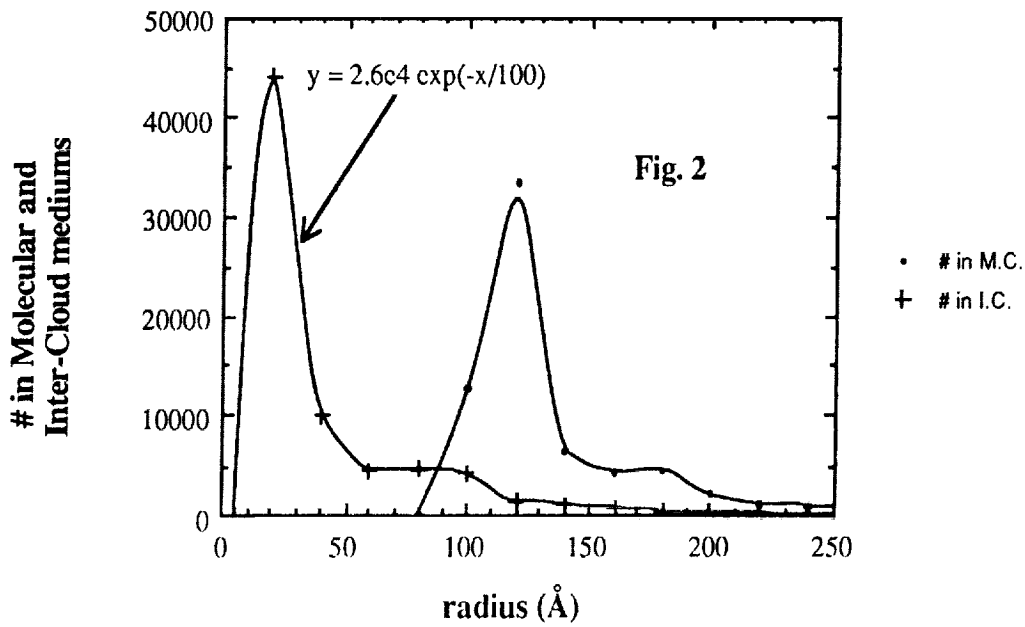
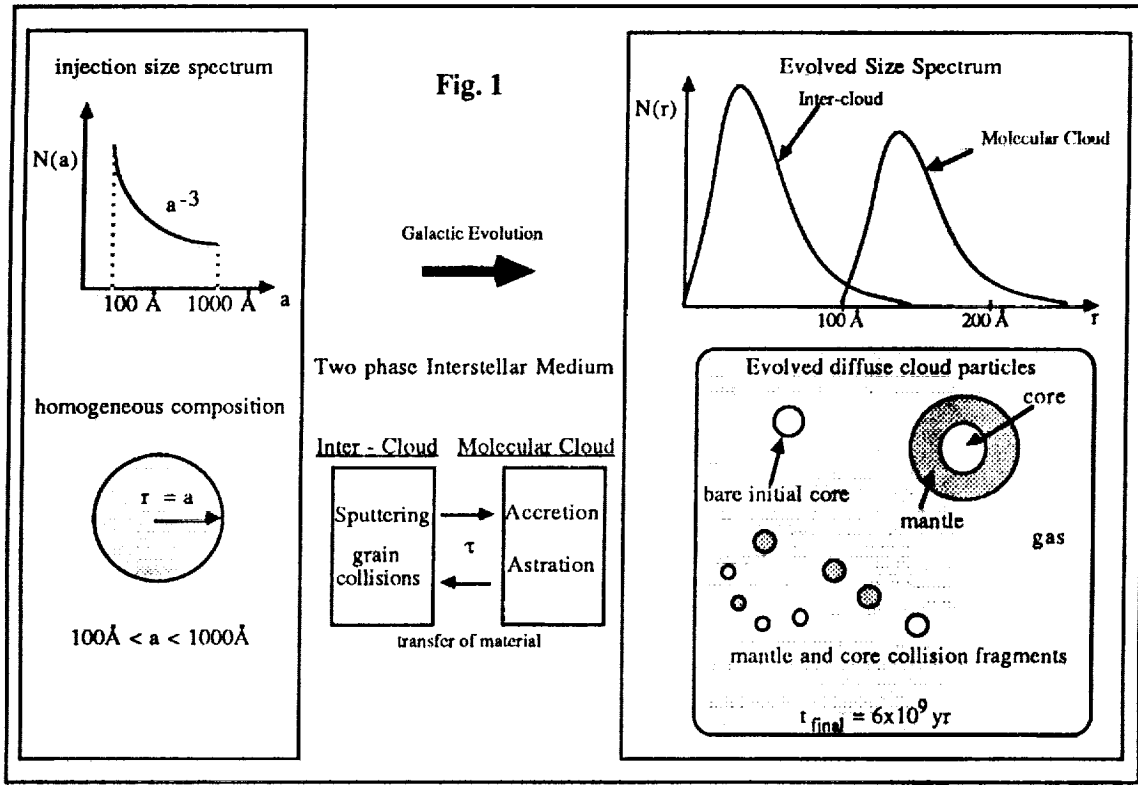

PROMPT GAMMA ACTIVATION ANALYSIS (PGAA): TECHNIQUE OF CHOICE FOR NONDESTRUCTIVE BULK ANALYSIS OF RETURNED COMET SAMPLES? David J. Lindstrom¹ and Richard M. Lindstrom² ¹Lockheed Engineering and Sciences Co. C-23, 2400 NASA Rd. 1, Houston, TX 77058; ²Center for Analytical Chemistry, National Institute of Standards and Technology, Gaithersburg, MD 20899.

Prompt gamma activation analysis is a well-developed analytical technique (1) that might well be the one of choice for multielement bulk analysis of returned comet samples. The technique involves irradiation of samples in an external neutron beam from a nuclear reactor, with simultaneous counting of gamma rays produced in the sample by neutron capture. Capture of neutrons leads to excited nuclei which decay immediately with the emission of energetic gamma rays to the ground state.

PGAA has several advantages over other techniques for the analysis of cometary materials:

1) It is nondestructive. Only a very small proportion of the atoms in the sample are altered. Residual radioactivity is minimal, and changes in isotopic ratios brought about by the irradiation are small and easily corrected for. Since the irradiation is conducted in a neutron beam outside the reactor, the samples can be kept at liquid nitrogen temperature during the measurement.

2) It can be used to determine abundances of a wide variety of elements, including most major and minor elements (Na, Mg, Al, Si, P, K, Ca, Ti, Cr, Mn, Fe, Co, Ni), volatiles (H, C, N, F, Cl, S), and some trace elements (those with high neutron capture cross sections, including B, Cd, Nd, Sm, and Gd). Accuracy is quite good due to the simple physics involved.

3) It is a true bulk analysis technique. Data from Comet Halley (e.g., 2) indicate that cometary material is quite inhomogeneous on the scale of individual grains, and larger inhomogeneities appear likely. Sample volumes as large as several cm³ are still nearly transparent to the neutrons and gamma rays involved in PGAA; matrix effects are minimal. Optimal sample sizes will probably be in the range of hundreds of milligrams to a few grams, depending on the relative amounts of ices and silicates.

Recent developments should improve the technique's sensitivity and accuracy considerably (3). The major improvement is the use of a "cold neutron" facility instead of a thermal reactor neutron beam. The first major cold neutron facility in this country is now being built at the National Institute of Standards and Technology. The system utilizes a liquid helium cooled block of D₂O ice to produce neutrons with thermal energies of about 60 Kelvin. These neutrons are then piped through neutron guides to an experimental station far from the reactor and far from most sources of instrumental background. The main advantages of cold neutrons are that cross sections are higher by about a factor of three than for "thermal neutrons" at 300 K, interfering reactions due to fast neutrons are minimized, and gamma ray backgrounds are greatly reduced.

PROMPT GAMMA ACTIVATION ANALYSIS
Lindstrom D.J. and Lindstrom R. M.

The maximum amount of information might be obtained from the following analytical scheme: 1) Package a bulk sample weighing perhaps two grams in a sealed Teflon bag and do PGAA analyses as described above, maintaining the sample at liquid nitrogen temperature with a stream of helium gas. When that analysis is complete, 2) transfer the sample to a vacuum line, puncture the container, and carefully distill off the volatiles. These volatiles could themselves be analyzed by PGAA for bulk H, C, and perhaps N contents. Residual solids, still in the original Teflon container, could 3) be re-analyzed by PGAA, and 4) irradiated for normal instrumental neutron activation analysis. This procedure would be essentially nondestructive and should produce reliable abundance estimates for some 40 elements. The same solid samples could be analyzed further by scanning electron microscopy and other techniques.

(1) Failey M. P., Anderson D. L., Zoller W. H., Gordon G. E., and Lindstrom R. M. (1979) Anal. Chem. 51, 2209-2221.

(2) Jessberger E. K., Christoforidis A., and Kissel J. (1988) Nature 322, 691-695.

(3) Lindstrom R. M., Zeisler R., and Rossbach M. (1987) J. Radioanal. Nucl. Chem. 112, 321-330.

SOLAR NEBULA CONDENSATES AND THE COMPOSITION OF COMETS; J.I. Lunine, Lunar and Planetary Laboratory, University of Arizona, Tucson.

A wealth of gaseous and condensed compounds have been identified in data from the Giotto and Vega flybys of Halley's comet, and from complementary ground-based studies of Halley and other recent comets. The interpretations in terms of cometary origin have been characterized by a high degree of selectivity of data in order to fit simple (and largely preconceived) models of particular astrophysical environments in which it is assumed comets formed.

In fact, if comets reveal anything about the origin of the solar system, it is that material which eventually went to form the planets passed through a number of stages of chemical and physical evolution in a range of environments from the interstellar medium through hot dense clouds in star-forming regions to the solar nebula. The degree to which the most refractory materials in comets were chemically processed and altered in these environments must of necessity be vastly different from that of the most volatile gases, such as methane and carbon monoxide. More precisely, grains containing silicate and heavy organic components may have been little affected by passage into the solar nebula and subsequent accretion processes, provided they remained on orbits far from the center of the nebula. On the other hand, molecular species such as methane, carbon monoxide, ammonia and perhaps water ice would have been lost from the grains at various stages in molecular clouds and during entry into the nebula. These species in Halley's comet may reflect the final stages of cometary accretion in the outer part of the solar nebula.

This talk focusses on interpretation of the volatile abundances in Halley's comet in terms of models for chemical and physical processes in the solar nebula. Key ratios of the oxidized and reduced species of nitrogen and carbon are identified which tell something of the chemical history of the environment in which cometary grains accreted to form the nucleus. Isotopic abundances are also applied to this problem. I will show that the abundances of methane and carbon monoxide are consistent both with models of solar nebula chemistry and chemical processing on grains in star-forming regions. Ultimately, limitations of the current data set on molecular abundances in comets and star-forming regions prevent a definitive choice between the two.

Processes important to the composition of outer solar system bodies are: Gas phase chemistry in the solar nebula: The models of Lewis and Prinn and Fegley (see Prinn and Fegley, 1989) for kinetic inhibition of homogeneous gas-phase, and heterogeneous grain-gas, reactions lead to the following conclusions: (a) the inner portion of the solar nebula (where reactions take place) is dominated by carbon monoxide and molecular nitrogen as the primary carbon- and nitrogen-bearing molecules. Carbon dioxide, methane and ammonia are minor constituents. Most of the elemental oxygen is bound up as carbon monoxide; water and silicates sequester the remainder. Possible depletion of water by diffusive redistribution (Stevenson and Lunine, 1988) leads to somewhat higher methane abundances in the inner nebula (Engel et al., 1988). Gas-grain catalysis may be effective only down to ~ 600 K, where it is poisoned by chemical combination of sulfur with metal grains (Fegley, 1988). In the higher pressure nebulae around giant planets, the results of the MIT group show that methane and ammonia may dominate, with water sequestering nearly the full elemental oxygen abundance.

Imperfect mixing in the solar nebula: Stevenson (1989) showed that radial mixing is severely limited in a viscous accretion disk model of the solar nebula, so that over 90% of the material in the outer solar nebula (>10 AU) has never been exposed to inner nebula chemistry. This dilutes the importance

SOLAR NEBULA CONDENSATES AND COMETS
LUNINE, J. I.

of methane and ammonia manufactured in the inner part of the disk, and suggests that chemical and physical processes in the surrounding molecular cloud and those associated with the molecular cloud-solar nebula interface could play an important role in determining outer solar system abundances. Also, mixing between giant planet sub-nebulae and solar nebula may affect the latter's composition (Prinn and Fegley, 1989).

Condensation: Concerning volatile species, condensation of water occurs in the solar nebula at roughly 150K. Condensation of ammonia hydrates using available ammonia occurs below 100K, and the diagnostic volatiles methane, carbon monoxide and molecular nitrogen condense at significantly lower temperatures (less than 40K). Of the last three only methane, if it is abundant, is predicted to condense in most models of the solar nebula pressure-temperature profile. The other volatiles must be trapped in less volatile condensates, most plausibly clathrated into or adsorbed on water ice. In giant planet sub-nebulae, the condensation temperatures of all species are raised by tens of degrees relative to the solar nebula.

Clathration: Trapping of small non-polar or weakly-polar species in clathrate hydrate is effective provided exposure of the ice to the gas is extensive. Formation of clathrate containing a particular guest molecule (e.g. methane) generally is thermodynamically favored at temperatures well above the condensation point of that particular species. The important exception in the nebula is carbon dioxide, but a significant fraction of that species could be trapped in mixed clathrates. Fractionation affecting the composition of trapped gas is significant in clathrate: methane is most easily incorporated, followed by carbon monoxide, and then argon and nitrogen. Objects formed in a solar nebula rich in carbon monoxide may still sequester quantities of methane significant in terms of surface composition.

Adsorption: Where clathrate formation is thermodynamically prevented or kinetically inhibited, physical adsorption of species onto water ice becomes an important trapping mechanism. Apparently amorphous ice has a much higher specific adsorption area than crystalline ice, approaching the carrying capacity of clathrate. Chemical fractionation effects in adsorption should be similar to that of clathration, but hard to predict because the distribution of void sizes in amorphous ice is very poorly known. There is some experimental evidence for low-temperature fractionation (Bar-Nun, 1988).

Processing of interstellar material: Pre-formed grains from interstellar clouds may undergo significant chemical processing in the course of entering the solar nebula. Such processing may occur at the nebula accretion shock, or during drag heating associated with infall. Only a modest (tens of degrees) increase in temperature is required to modify the most volatile components carried into the nebula by small grains.

REFERENCES

- Bar-Nun, A. 1988, XXVII Plenary Meeting of COSPAR Abstract Book, p. 205.
 Engel, S., Lewis, J.S. and Lunine, J.I. 1988, B.A.A.S. 20, in press.
 Fegley, B., Jr. 1988, in Workshop on the Origins of Solar Systems, eds. J.A. Nuth and P. Sylvester, (LPI Tech. Report 88-04), p. 51.
 Prinn, R.G. and Fegley, B., Jr. in Planetary and Satellite Atmospheres: Origin and Evolution, eds. S.K. Atreya, J.B. Pollack and M.S. Matthews, (Tucson: Univ. of Arizona Press), in press.
 Stevenson, D.J. 1989, Astrophys. J., in press.
 Stevenson, D.J. and Lunine, J.I. 1988, Icarus 75, 146.

CANDIDATE SAMPLE ACQUISITION SYSTEMS FOR THE ROSETTA MISSION; P.G. Magnani, C. Gerli, G. Colombina - Tecnospazio S.p.A and P. Vielmo - Tecnomare S.p.A

The Comet Nucleus Sample Return (CNSR) mission, one of the four cornerstone of ESA Scientific program, is one of the most complex space venture within the next future, both from technological and deep space exploration point of view. In the Rosetta scenario the Sample Acquisition Phase represents the most critical point for the global mission success. This mission in fact cannot be considered neither a "standard" space program nor a "standard" earth sampling program. The proposed paper illustrates the main results obtained by Tecnospazio/Tecnomare in the context of the CNSR-SAS on going activity.

The main areas covered are related to :

- * Sample properties characterization
 - comet soil model
 - physical/chemical properties
 - reference material for testing
- * Concepts identification for
 - coring
 - shovelling
 - harpooning
 - anchoring
- * Preferred concept
 - trade off among concepts
 - identification of the preferred configuration
- * Proposed development activity for gaining the necessary confidence before finalizing the CNSR mission.

Particular emphasis will be given to the robotic and flexibility aspects, of the identified SAS configuration, intended as a means for the overall system performance enhancement.

INTERSTELLAR AND COMETARY DUST

John S. Mathis, Washburn Observatory, Univ. of Wisconsin-Madison

My talk will outline the aspects of interstellar dust which are known from direct observations. Then I will discuss several theoretical interpretations which have been advanced, highlighting first their similarities and then discussing their differences. I will mention several problems which are not understood on the basis of any present theory, and why the observations are so puzzling. I will comment on some specific difficult various theories have in explaining the observations, and in particular why it does not seem likely to me that interstellar dust grains have very important mantles of organic refractory materials or anything else. I will then discuss my own ideas about the conditions of interstellar dust throughout its life cycle, from birth to incorporation in pre-cometary ices. I will not discuss what kinds of processing might occur between the grains being incorporated into an icy matrix and the ices forming a comet.

Dust is primarily observed by its effects on the spectra of background stars, so observations at optical and ultraviolet (UV) wavelengths are confined to the diffuse interstellar medium (ISM) or to the outer regions of dense clouds. Within this somewhat limited range of environments there are very few lines of sight which show any evidence for icy mantles, but there are major variations in the wavelength dependence of the extinction. In the infrared region of the spectrum it is possible to observe a few stellar source deeply embedded within molecular clouds-- in this case, the dust clearly has accreted thick icy mantles containing a wide variety of molecules.

There are several observed facts about the interstellar extinction law, or the dependence of the extinction on wavelength, about which there is little controversy. These include:

(a) There are not many spectral features in the extinction law for the diffuse ISM, a fact has been the downfall of countless suggestions for the materials which might be present in space. The features which are present are 9.7 and 18 μm broad absorption features which are very well matched by the spectra of amorphous silicates. The same features are seen in emission in the spectra of oxygen-rich red giant stars. From these facts, it is generally accepted that silicates are present as a major constituent of dust. (b) There are emission bands in the 3 - 13 μm range and associated continuum found in the spectra of a wide variety of objects. The wavelengths of the bands coincide very well, but not perfectly, with the spectra of polycyclic aromatic hydrocarbons (PAHs), but other forms of hydrogenated carbon cannot be excluded. (c) There is a huge spectral feature at 2175 \AA which has many puzzling characteristics. It is so large that it must be carried by a very abundant element or ion. It coincides with the wavelength at which graphite has a strong resonance, but there are difficulties with the graphite identification which will be mentioned. (d) The various extinction laws over the entire observed wavelength range, 0.1 - 5 μm , represent a regular progression with just one parameter. This parameter can be taken to be some measure of the curvature of the extinction law in either the optical or the UV part of the spectrum.

There are several theories which attempt to explain the observations. I will review those by Greenberg, Duley/Williams, Draine/"MRN", and composite grains very briefly. In general, they agree that the major constituents of dust are silicates and a form of carbon, at least some of which also contains hydrogens bonded to it. To produce the observed polarization, the grains must be nonspherical and capable of being aligned by the rather weak galactic magnetic field, even in regions of very high gas density. The theories differ considerably in the arrangement of the carbonaceous materials. Greenberg and Duley/Williams want mantles on silicate cores, while the others want bare grains in the diffuse ISM and the outer regions of dense clouds. The reasons why mantles do not seem to be important in the diffuse ISM are discussed. All of the various theories seem capable of explaining the main features of at least the average extinction law and polarization in the diffuse ISM.

The weaknesses of each theory, as I see them, are reviewed, and tests are discussed. One is the prediction of the polarization and extinction of the infrared silicate band, which is sensitive to the immediate environment of the silicates which are present in the grains-- that is, whether or not there is a surrounding mantle. Observations indicate that there is not. Another test is whether or not a given type of model can explain in a reasonable way the regular progression from the average interstellar extinction law in the diffuse ISM to that in the outer regions of dense clouds. The grains appear larger in clouds, and yet the extinction per H atom is smaller in some well-observed cases. These observations show that grains in these outer regions grow by sticking together (coagulation) rather than by accreting mantles.

A rather speculative scenario of how a given particle of refractory material cycles into and out of the diffuse ISM and dense clouds is presented. Part of the process is, indeed, related to the mantles which are known to be present deep within clouds. A possible state of the grain when it is incorporated into pre-cometary material is described. Whether or not the grain is further processed in between the dense-cloud phase and being deposited deep within a cometary nucleus is considered too speculative to discuss.

The In-situ Cometary Particulate Size Distribution Measured For One Comet: P/Halley;
 J.A.M. McDonnell and G.S. Pankiewicz,
 Unit for Space Sciences, University of Kent at Canterbury, Kent, U.K.

The close approach of Giotto to comet Halley during its 1986 apparition offered a unique opportunity to study the particulate mass distribution to masses of up to one gram. Data acquired by the front end channels of the highly sensitive mass spectrometer PIA (1) and the dust shield detector system, DIDSY (2), provide definition of the detected distribution as close as 1000km to the nucleus.

Dynamic motion of the particulates after emission leads to a spatial differentiation affecting the size distribution in several forms:

- (i) Ejecta velocity dispersion. Ejection velocities are governed by gas drag from the nucleus surface and are sensitive to grain cross-sectional areas. This results in mass distributions changing significantly (and independently of (ii) below) far from the nucleus. Velocity dispersion is of particular importance in locating nucleus source regions for grains measured simultaneously, but of differing masses.
- (ii) Radiation pressure. After emission from the nucleus, solar radiation pressure provides a force which can effectively be considered as a radially reduced heliocentric gravitational field, but size dependent. Under the differential effect of radiation pressure combined with (i), spatial segregation results. The familiar envelopes (3) may change drastically according to grain optical properties.
- (iii) Varying heliocentric distance. Earlier approaches to dust modelling excluded the effect of changing heliocentric distance over the relatively short times of flight concerned. This does however cause the very slowly moving particles ($< 100\text{ms}^{-1}$) to move ahead of the comet orbit (ejection sunward) or behind, producing spiralling trajectories (4) rather than simpler parabolae. Envelopes become less distinct with decreasing particles terminal velocity, until no such behaviour is observed.
- (iv) Anisotropic nucleus emission. Spatial (active nucleus spots) and temporal (burst) variations result in jetting enhancements; together with rotational behaviour of the nucleus, these may provide complex time varying changes to mass distributions throughout the coma.

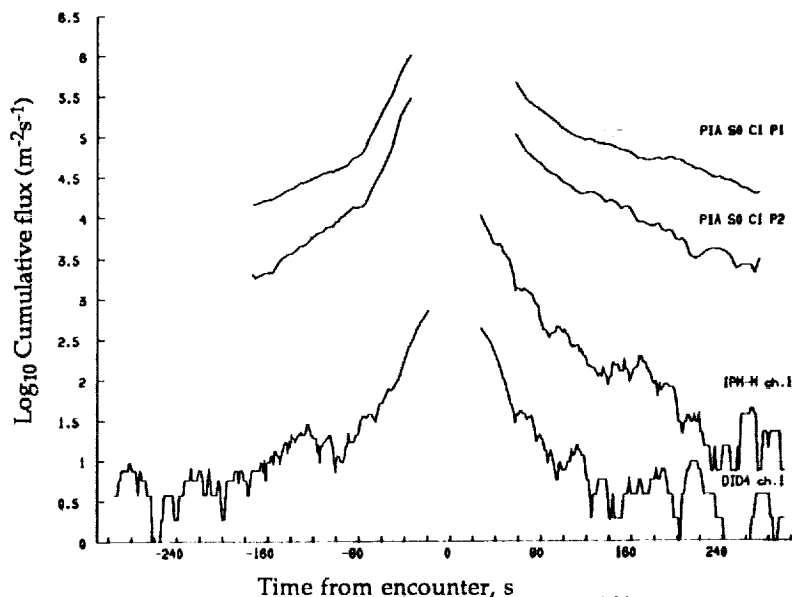

Figure 1: Cumulative flux - time profiles are given for the following Giotto dust sensors: PIA (masses $> 10^{-17}\text{kg}$), PIA ($> 5 \times 10^{-15}\text{kg}$), IPM-M channel 1 ($> 5 \times 10^{-13}\text{kg}$) and DID 4 (small sector) channel 1 ($> 5 \times 10^{-12}\text{kg}$) - see (2) for instrument details. The mass distribution is seen to close together the profiles at smaller masses.

Examining time profiles of the PIA and DIDSY fluxes over 10 minutes around closest approach (figure 1), we ask firstly how these effects are observed and secondly how they may be incorporated to yield a size distribution close to the probable refractory particulate distribution in the nucleus:

Jets and Nucleus Anisotropy. Clear enhancements (jets) above a fountain model distribution are observed to produce flux increases of up to an order of magnitude (DID4 channel 1 at +220s in figure 1). Displacements in each mass range indicate that velocity dispersion as a result of nucleus rotation is present (5). In containing dust over a large mass range, each jet has a mixed history: a lack of large

grains may indicate recent spot switch-on. Since however jets are seen across the mass spectrum, it is likely that active regions are long-lived, staying active over the greater part of the nucleus' day.

Coma Dynamical Processes. Distinct envelopes early and later on during the encounter ($\sim 10^5$ km away from the nucleus) are not clearly seen, indicating velocity spread at a given grain size. No sharp terminator either is seen, although an asymmetry at smaller masses is observed with fluxes over sunlit regions enhanced by a factor of three. The changing mass distribution is clear, with a 2.7 order of magnitude mass difference between PIA channels showing less than 1 order of magnitude in flux.

Particulate Metamorphosis Within The Coma. Relative to known processes in the coma, most phenomena are explicable without the need for substantial changes in particle nature, at least to nuclear distances of 1000 km. Data from camera observations (6) suggest that this is not substantially different down to the scale of less than the cometary radius, although departures from a $1/R^2$ spatial dependence are often observed. This departure does not imply directly that the source size distribution is changing, perhaps more the effects of anisotropy of the emission processes and coma dynamics.

Fragmentation has been suggested variously by Simpson (7) and yet the data presented here does not call for this being significant in terms of the measured in-situ distribution. The friable nature and low density of cometary particulates is well known and it would be rare if these did not fragment. A destruction of *one* large grain could result in some 10^{10} particles detectable by DIDSY and 10^{16} particles detectable by PIA! This mechanism is not therefore dominant and scarcely affects the relationship between in-situ and nucleus particulate distributions.

Transformation of the in-situ distribution from PIA and DIDSY weighted heavily by the near-nucleus fluxes leads to the presumed nucleus distribution of figure 2. The data lead to a puzzling distribution at large masses, not readily explained in an otherwise monotonous power law distribution. Although temporal changes in nucleus activity could and do modify the in-situ size distribution, such an explanation is not wholly possible, because the same form is observed at differing locations in the coma where the time of flight from the nucleus greatly varies. Thus neither a general change in comet activity nor spatial variations lead to a satisfactory explanation. The paper will examine possible reasons for this and implications arising from the distribution relevant to remote and in-situ sampling operations in the vicinity of a cometary nucleus.

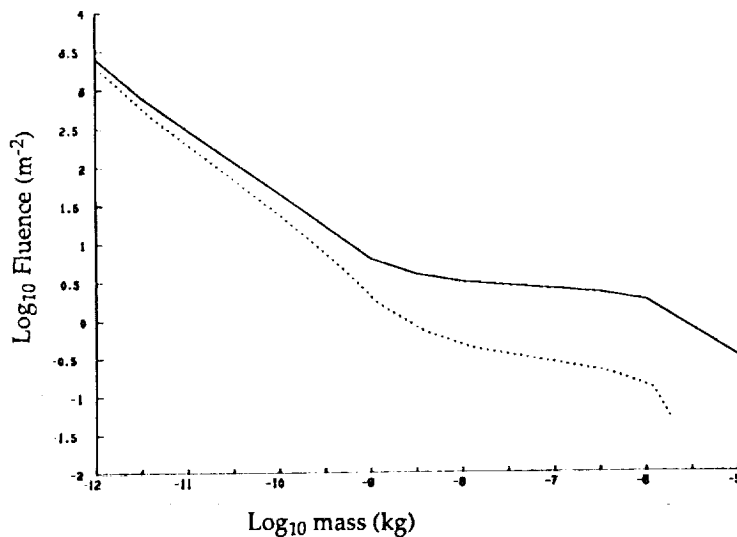

Figure 2: The mass distribution measured by DIDSY sensors is shown (solid line) during the period -450s to -169s (before encounter). A second distribution is also given (dotted line), transformed to the nucleus with a specific velocity assumption. This results in a steeper distribution, since the source fluence \sim velocity \sim mass^{-0.18}.

1. Kissel J. (1986) *ESA SP-1077*, p.67-83.
2. McDonnell J.A.M. (1987) *J. Phys. E.*, p.741-758.
3. Divine N. (1981) *ESA SP-174*, p.25-30.
4. Fertig J. and Schwehm G.H. (1984) *Adv. Space Res.*, p.213-216.
5. Pankiewicz G.S. *et al.* (1988) *Adv. Space Res.*, in press.
6. Thomas N. and Keller H.U. (1987) *ESA SP-278*, p.337-342.
7. Simpson J.A. *et al.* (1988) *Adv. Space Res.*, in press.

EVOLUTION OF CARBONACEOUS CHONDRITE PARENT BODIES: INSIGHTS INTO COMETARY NUCLEI? Harry Y. McSween, Jr., Department of Geological Sciences, University of Tennessee, Knoxville, TN 37996-1410.

Much of the excitement about obtaining cometary samples accrues from the conventional view that they will comprise the most primitive materials that we can get our hands on. Although "parent body" alteration of such samples would not necessarily detract from this interest, we should keep in mind the possibility that modification processes may have affected cometary nuclei. Inferences about the kinds of modifications that might be encountered can be drawn from data on the evolution of carbonaceous chondrite parent bodies. The following observations suggest that, of all the classes of chondrites, these meteorites are most applicable to the study of comets: (a) Carbonaceous chondrites are chemically the most primitive meteorites. The elemental abundances of CI chondrites provide the closest match with the composition of the solar photosphere; (b) Spectral reflectivity surveys of asteroids suggest that carbonaceous chondrite-like bodies reside primarily in the outer asteroid belt. Their formation locations thus lie closer to inferred comet accretion sites [1]; (c) Petrographic studies of carbonaceous chondrites indicate that they formed in volatile-rich environments, and H₂O and other volatiles may have been incorporated initially as ices [2]; (d) Some types of chondritic interplanetary dust particles (IDPs), which may be solid debris from short period comets, are mineralogically similar to carbonaceous chondrites [3]. Moreover, both of these materials appear to be broadly similar in composition to Comet Halley dust [4].

Most carbonaceous chondrites show evidence of parent body heating, commonly in the form of aqueous alteration. Although aqueous alteration clearly took place at low temperatures [5], heat was necessary to produce water from ice. Decay of short-lived radionuclides like ²⁶Al is one plausible heating mechanism for asteroids that could presumably affect comets as well. External heat sources such as electromagnetic induction by a massive solar wind have also been suggested for asteroids, but the decrease in effectiveness of this mechanism with solar distance renders this heat source unlikely for cometary bodies. An additional heat source for comets could be provided by close passage near the sun, or near passing stars in the Oort cloud.

Melting of ice in carbonaceous chondrite parent bodies resulted in profound mineralogical changes. The original (presumed anhydrous) chondrite assemblage has been altered to intimate mixtures of fine-grained phyllosilicate minerals like serpentine, smectite, chlorite, as well as poorly crystallized oxides, hydroxides, and other complex phases [3,6]. It is generally believed that chemical changes accompanying aqueous alteration were minor, although this conclusion is based primarily on similarities to solar elemental abundances which are not precisely measured. The strongest reported enrichments of the heavy isotopes of O, N, and C occur in chondrites which have been exposed to aqueous alteration [7]. Thermal models for ice-bearing planetesimals [8] indicate that ice acts as a thermal buffer, accounting for the difference in metamorphic history between parent bodies for ordinary and carbonaceous chondrites.

Virtually all classes of meteorites show the effects of impact processes, and it seems possible that cometary materials may have experienced impacts before or possibly after accretion. Shock metamorphic effects include partial destruction of the crystal structures of many minerals, recognizable from their optical and X-ray diffraction properties.

Uniaxial compaction and deformation of chondrules in a few carbonaceous chondrites have also been recognized [9]. Most, if not all, carbonaceous chondrites are breccias, containing clasts with variable alteration histories. Shock can also cause dehydration of phyllosilicates [10], although evidence for this process has not been recognized in carbonaceous chondrites.

Many chondrites have been irradiated by solar wind, solar flare, and cosmic ray particles. The penetration depths for these particles vary with their energies, but none can penetrate appreciable depths. For this reason, most chondrite irradiation occurred in regoliths on parent body surfaces or during exposure as small meteoroids in space. A high proportion of carbonaceous chondrites contain solar-wind implanted noble gases, as well as significant amounts of cosmogenic nuclides and solar flare tracks in mineral grains [11].

How applicable, if at all, are these processes to comets? If the proportion of possible internal heat sources such as ^{26}Al in cometary materials are similar to those in chondrites, and if the time scale of comet accretion was fast enough to permit incorporation of "live" radionuclides, comets might have had early thermal histories somewhat like those of carbonaceous chondrite parent bodies. We might then predict that cometary dust should contain some phyllosilicate minerals and other phases formed by aqueous alteration. At least some chondritic IDPs contain phyllosilicates. However, similarities between the chemical compositions of anhydrous IDPs and Comet Halley dust [4] may suggest that aqueous alteration processes have not appreciably affected this cometary nucleus. Impact processes possibly affected cometary materials during their initial accretion, and possibly during ejection from the outer solar system into the Oort cloud. We should be prepared to find that comets are heterogeneous, consisting of rock fractions with different thermal and shock histories. In fact, the comet nucleus itself may ultimately be viewed as a megabreccia, comprised of rock and ice blocks and clasts. The shielding characteristics of ice are similar to that of rock, and along with the unlikelihood of comet regoliths, this might suggest that irradiation of cometary materials is unlikely. However, conceptions of comet surfaces that envision dusty mantles or icy pedestals capped by dust certainly offer opportunities for sample irradiation, and cosmic ray tracks have been observed in chondritic IDPs.

REFERENCES

- [1] Hartmann W.K., Tholen D.J. and Cruikshank D.P. (1987) Icarus 69, 33.
- [2] Prinn R.G. and Fegley B. (1988) Origin Evol. Planet. Atmos., in press.
- [3] Tomeoka and Buseck (1988) GCA 52, 1627.
- [4] Rietmeijer F.J.M. (1987) LPS XIX, 980.
- [5] Clayton R.N. and Mayeda T.K. (1984) EPSL 67, 151.
- [6] McSween H.Y. (1985) Rev. Geophys. Space Phys. 17, 1059.
- [7] Bunch T.E. and Chang S. (1980) GCA 44, 1543.
- [8] Grimm R.E. and McSween H.Y. (1987) LPS XIX, 427.
- [9] Cain P.M., McSween H.Y. and Woodward N.B. (1986) EPSL 77, 165.
- [10] Lange M.A. and Ahrens T.J. (1982) LPS XIII, 421.
- [11] Goswami J.N., Lal D. and Wilkening L.L. (1984) Space Sci. Rev. 37, 111.

THE COMET RENDEZVOUS ASTEROID FLYBY MISSION: David Morrison, NASA Ames Research Center, Moffett Field, CA, Marcia Neugebauer and Paul Weissman, Jet Propulsion Laboratory, Pasadena, CA.

The ultra-fast flybys of Comet Halley in 1986 by the Vega, Suisei, and Giotto spacecraft gave us our first close glimpse of a cometary nucleus and the first in situ measurements of the complex physical and chemical processes occurring in the cometary coma and ionosphere. Many of our basic ideas regarding comets were confirmed, such as the existence of an icy conglomerate nucleus, but many new facts and phenomena were also revealed. For example, the nucleus was found to contain a substantial amount of complex organic material, and hydrocarbon grains were shown to play an important role in the chemical kinetics in the cometary coma. The cometary nucleus was shown to be very dark and highly irregular, but relatively little was learned about its detailed structure, density, and surface morphology.

The Comet Rendezvous Asteroid Flyby (CRAF) mission is designed to answer the many questions raised by the Halley missions by exploring a cometary nucleus in detail, following it around its orbit and studying its changing activity as it moves closer to and then away from the Sun. In addition, on its way to rendezvous with the comet, CRAF will fly by a large, primitive class main belt asteroid and will return valuable data for comparison with the comet results. The selected asteroid is 449 Hamburga with a diameter of 88 km and a surface composition similar to carbonaceous chondrite meteorites, and the expected flyby date is January, 1998.

The present target for CRAF is short-period comet Kopff which orbits the Sun every 6.4 years with a perihelion distance of 1.58 AU. Following launch in August, 1995 and an Earth gravity-assist flyby in 1997, the CRAF spacecraft will rendezvous, that is it will match orbits, with comet Kopff near its aphelion (close to Jupiter's orbit) in August, 2000. During the early stages of the rendezvous when the nucleus is inactive, the CRAF spacecraft will make several slow flybys and then be placed in orbit around the nucleus at an altitude of 30 to 100 km. From this altitude it will image the nucleus surface at a resolution of better than 1 meter/line-pair and produce both infrared and thermal maps of the surface. Sampling instruments onboard the spacecraft will measure the elemental and molecular composition of the outflowing gas and dust particles, and a scanning electron microscope will image individual dust grains at a resolution of 0.04 micrometers. A dust impact counter will provide detailed measurements of the dust flux as well as an onboard warning of dangerously high dust levels. Fields and particles instruments will measure the interaction of the nucleus and its tenuous atmosphere with the solar wind. During this phase the spacecraft will be placed in a very low orbit for several revolutions to precisely determine the comet's mass (and hence, density) and gravitational harmonics.

About a year after rendezvous, the spacecraft will fire an instrumented penetrator into the Kopff nucleus surface from an altitude of 6 to 10 km. The instrument complement on the 1.5-meter long, golf tee-shaped penetrator includes: accelerometers to determine the strength of surface materials and any layering if it exists, a gamma-ray spectrometer for elemental composition measurements, passive and active temperature sensors for measuring thermo-physical properties of the cometary ices, and a differential scanning calorimeter and evolved gas analyzer for determining the molecular

composition of the cometary materials. Remote sensing instruments onboard the CRAF orbiter will observe the penetrator impact and compositional instruments will analyze material blown off the nucleus surface. The penetrator will operate on the surface of the Kopff nucleus for about 10 days. The CRAF spacecraft may carry a second penetrator if sufficient launch mass margin exists.

The CRAF spacecraft will continue to make measurements in orbit around the cometary nucleus as they both move closer to the Sun, until the dust and gas hazard becomes unsafe. At that point the spacecraft will move in and out between 50 and 2,500 kilometers to study the inner coma and the cometary ionosphere, and to collect dust and gas samples for onboard analysis. Following perihelion, the spacecraft will make a 50,000 km excursion down the comet's tail, further investigating the solar wind interaction with the cometary atmosphere. The spacecraft will return to the vicinity of the nucleus about four months after perihelion to observe the changes that have taken place. If the spacecraft remains healthy and adequate fuel is still onboard, an extended mission to follow the comet nucleus out to aphelion is anticipated.

The CRAF mission will be the first to employ the Mariner Mark II spacecraft. Mariner Mark II is a new, 3-axis stabilized, Voyager class spacecraft for exploring the outer solar system and small bodies. Its modular design allows it to be readily adapted for a variety of missions while retaining many common spacecraft subsystems and utilizing a common multi-mission ground operations system. The propulsion module for the CRAF spacecraft is provided by the Federal Republic of Germany which also is providing one of the scientific experiments. Current plans are to build a Saturn Orbiter/Titan Probe (Cassini) spacecraft at the same time as CRAF, with the European Space Agency providing the Titan Probe and several of the scientific instruments on both the orbiter and the probe. The Cassini mission is expected to be launched in April, 1996 and includes a flyby of asteroid 66 Maja.

The selected scientific investigations on CRAF include 137 researchers from seven countries, with over 25% coming from outside the United States. Additional participating scientists will be selected by NASA to enhance the scientific expertise for key mission phases as asteroid, comet, and cruise science data become available.

CRAF results are expected to shed new light on the composition of the primordial solar nebula, on chemical evolution in the nebula, and on accretionary processes at both microscopic and macroscopic scales. These measurements will help to constrain current solar nebula models, and will provide an important link between astrophysical studies of the interstellar medium and star formation, and planetary studies of these most primitive of solar system bodies. CRAF will provide a fundamental understanding of complex cometary processes, including chemical kinetics in the coma and the solar wind interaction, both of which have important astrophysical applications. In addition, CRAF is expected to provide important data on the role of comets in contributing to the volatile reservoirs on the terrestrial planets and on outer solar system satellites, and in possibly bringing pre-biotic material to the Earth.

MEASUREMENTS OF LONG-LIVED COSMOGENIC NUCLIDES IN RETURNED COMET NUCLEUS SAMPLES

K. Nishiizumi, C. P. Kohl, and J. R. Arnold
Dept. of Chemistry, B-017, Univ. of California, San Diego, La Jolla CA 92093

Measurements of long lived cosmic ray produced radionuclides have given much information on the histories and rates of surface evolution for meteorites, the moon and the earth [e.g. 1]. These nuclides can be equally useful in studying cometary histories and post nebular processing of cometary surfaces. The concentration of these nuclides depends on the orbit of the comet (cosmic ray intensity changes with distance from the sun), the depth of the sampling site in the comet surface, and the rate of continuous evolution of the surface (erosion rate of surface materials). If the orbital parameters and the sampling depth are known, production rates of cosmogenic nuclides can be fairly accurately calculated by theoretical models [2] normalized to measurements on lunar surface materials and meteoritic samples. Due to the continuous evaporation of surface materials, we expect the long lived radioactivities to be undersaturated. Accurate measurements of the degree of undersaturation in nuclides of different half-lives allow us to determine the rate of surface material loss over the last few million years.

Solar cosmic ray (SCR) production in the surface layer can give the most precise information about the rates of evaporation and dust evolution in the sampled region. While many comets spend very little time within the region of the solar system where SCR effects are significant, a short period comet should have a higher measurable component of these nuclides in near-surface layers. The mission target will of course be a short-period comet. We can make detailed estimates when this comet is selected.

One must pay attention to the nature of the region where the samples are taken. If it is an active region of gas and dust emission, the SCR effect will be removed once each orbit near perihelion. If it is an inactive region, the SCR products can accumulate throughout the comet's lifetime as a short-period object. This offers us the opportunity to date the orbital perturbation which brought the comet into the present short-period regime.

The nuclides which we propose to measure are ^{10}Be (half-life = 1.5 My), ^{26}Al (0.7 My), ^{36}Cl (0.30 My), ^{41}Ca (0.1 My), and ^{53}Mn (3.7 My). All nuclides should be measured in silicate separates, i.e. dust particles, and ^{10}Be should also be measured in ice and in carbon separately. We have measured these nuclides (except ^{41}Ca) in less than 1 mg of deep sea particles and in lunar rocklets using AMS (Accelerator Mass Spectrometry) and neutron activation (^{53}Mn) [e.g. 3,4]. The present detection limit of AMS is on the order of 10^6 atoms or less. A few to 10 mg of silicate separate would enable us to measure all five nuclides proposed with less than 10 % error. These measurements could be performed today, using existing technology, except for ^{41}Ca which is being studied and is expected to be measurable at these levels within a year. A very useful set of samples would consist of a surface sample (0-a few cm depth) and a series of core samples at depths down to 1 m, ideally 10 samples at intervals of 10 cm. Alternatively a large diameter short core to 20 cm depth would enable us to give better resolution to surface processes. A surface sample of a few mg ice and a few mg carbon is needed for the additional ^{10}Be measurements. It is extremely important that the depths below cometary surface be known for all samples.

The depth profile of activity in the top 100 g/cm² (or more) offers another interesting possibility: to determine production rates and hence the cosmic-ray flux outside the sun's magnetosphere. Because the sun's magnetic

field removes many lower-energy galactic cosmic ray (GCR) particles, production rates due to GCR irradiation are usually low at the surface and increase with depth. Beyond the magnetosphere the lower energy particles would raise the production at the surface and the measured profiles should be qualitatively different. The results should be very interesting for cosmic-ray physics.

Short half-lived nuclides such as ^7Be , ^{22}Na , ^{54}Mn , and ^{60}Co are less favorable for this work because of the long transportation time of the sample return. The radioactivity produced in the comet would decay appreciably during the transportation and measurable amounts of the nuclides would be produced by cosmic ray bombardment in the space probe unless the sample is encased in massive shielding. In addition, the high detection limit due to direct decay counting of these short lived nuclides requires larger sample sizes for the same precision. In-situ measurements of such nuclides should be considered.

References

1. Langevin, Y, Arnold, J. R. and Nishiizumi, K. (1982) *J. Geophys. Res.*, 87, 6681-6691.
2. Reedy, R. C. and Arnold, J. R. (1972) *J. Geophys. Res.*, 77, 537-555.
3. Nishiizumi, K. (1983) *Earth Planet. Sci. Lett.*, 63, 223-228.
4. Nishiizumi, K., Arnold, J. R., Klein, J., Middleton, R. and Goswami, J. N. (1985) *Lunar Planet. Sci. XVI*, (Lunar Planet. Inst., Houston), 620-621.

Metamorphism of Cosmic Dust: Processing from Circumstellar
Outflows to the Cometary Regolith

Joseph A. Nuth III

Code 691, Astrochemistry Branch
Laboratory for Extraterrestrial Physics
NASA/Goddard Space Flight Center
Greenbelt, MD 20771

Nucleation is a non-equilibrium process: the products of this process are seldom the most thermodynamically stable condensates but are instead those which form fastest. It should therefore not be surprising that grains formed in a circumstellar outflow will undergo some degree of metamorphism if they are annealed or are exposed to a chemically active reagent. Metamorphism of refractory particles continues in the interstellar medium (ISM) where the driving forces are sputtering by cosmic ray particles, annealing by high energy photons and grain destruction in supernova generated shocks. Studies of the depletion of the elements from the gas phase of the interstellar medium tell us that if grain destruction occurs with high efficiency in the ISM, then there must be some mechanism by which grains can be formed in the ISM. Various workers have shown that refractory mantles could form on refractory cores by radiation processing of organic ices. A similar process may operate to produce refractory inorganic mantles on grain cores which survived the supernova shocks. Most grains in a cloud which collapses to form a star will be destroyed; many of the surviving grains will be severely processed. Grains in the outermost regions of the nebula may survive relatively unchanged by thermal processing or hydration. It is these grains which we hope to find in comets. However, only those grains encased in ice at low temperature can be considered pristine since a considerable degree of hydrous alteration might occur in a cometary regolith if the comet enters the inner solar system.

Some discussion of the physical, chemical and isotopic properties of a refractory grain at each stage of its life cycle will be attempted based on the limited laboratory data available to date. Suggestions will be made concerning the types of experimental data which are needed in order to better understand the processing history of cosmic dust.

MICROANALYTICAL CHARACTERIZATION OF BIOGENIC COMPONENTS OF INTERPLANETARY DUST;* Filippo Radicati di Brozolo, G. P. Meeker and Ronald H. Fleming, CHARLES EVANS & ASSOCIATES, Redwood City, CA

The elemental, isotopic, textural, and molecular analysis of interplanetary dust particles (IDP) presents a unique opportunity for the study of the origin of prebiological organic molecules in the early solar system and perhaps even in the interstellar medium.¹ Programs are now under way to obtain pristine IDP from low earth orbits and from comet rendez-vous missions. The analysis of these pristine materials will require a new level of sophistication in sample handling, preparation and analysis. We report the early results of our study in the development of new microanalytical characterization techniques for the study of biogenic components in pristine interplanetary dust.

We have developed a procedure to embed small particles in a non-organic medium for the preparation of microtome cross sections. The particles are gold coated, embedded in indium and heated to form an indium-gold alloy. Cross sections of a small Murchison meteorite matrix particle have been obtained which show the particle to be totally surrounded by AuIn₂. This technique was developed using class 100 clean room conditions and can be applied without modification to IDP.

A secondary ion mass spectrometry (SIMS) study of IDP has also been successful. We have developed the ability to produce quantitative isotope ratio images of cross sections of IDP. We have demonstrated the technique by measuring inhomogeneous deuterium excesses in IDP with a lateral resolution of ~2 μm . The deuterium anomalies detected with this technique provide clear evidence for the extraterrestrial origin of the IDP particles analyzed.² The particles are preserved for further study by other analytical techniques such as TEM and laser ion mass spectrometry.

We have performed a systematic study of laser desorption and ionization for the analysis of selected model organic species and fragments of the Murchison meteorite using both single and double laser configurations of the Cambridge Mass Spectrometry LIMA 2A instrument. We have identified appropriate instrumental conditions (including several substrate materials) for the laser desorption/ionization analysis of organic species in extraterrestrial materials.

REFERENCES

1. J. A. Wood and S. Chang, Eds., The Cosmic History of the Biogenic Elements and Compounds, NASA SP-476, 80 (1985).
2. K. D. McKeegan, R. M. Walker, and E. Zinner, *Geochim. Cosmochim. Acta*, 49, 1971 (1985).

* Supported by NASA SBIR contract NAS2-12818

WHAT IF CHONDRITIC POROUS INTERPLANETARY DUST PARTICLES ARE NOT THE REAL McCOY?

Frans J. M. Rietmeijer, Department of Geology, University of New Mexico, Albuquerque NM 87131, USA.

To select a target comet for a Comet Nucleus Sample Return Mission [CNSRM] it is necessary to have an experimental data base to evaluate the extent of diversity and similarity of comets. For example, the physical properties (e.g., low density) of chondritic porous [CP] interplanetary dust particles [IDPs] are believed to resemble these properties of cometary dust¹ although it is yet to be demonstrated that the porous structure of CP IDPs is inherent to presolar dust particles stored in comet nuclei. Porous structures of IDPs could conceivably form during sublimation at the surface of active comet nuclei². Porous structures are also obtained during annealing of amorphous Mg-SiO smokes which initially forms porous aggregates of olivine + platy tridymite and which, upon continued annealing, react to fluffy enstatite aggregates³. It is therefore uncertain that CP IDPs are entirely composed of unmetamorphosed presolar dust. Conceivably, new minerals and textures may form *in situ* in nuclei of active comets as a function of their individual thermal history.

CP IDPs include loosely packed aggregates (<50 μm in size) of many thousands of grains, usually <0.1 μm in size, of variable chemistry and structural state⁴ and fluffy aggregates of granular units (1-2 μm in size) forming a matrix for platy and euhedral single crystals. The chondritic nonporous, granular units consist of ultrafine-grained (0.002 - 0.1 μm in size) platy Mg-rich silicates, sulfides and oxides in carbonaceous material^{5,6}. A broad classification scheme includes (1) olivine- and pyroxene-rich (= anhydrous) IDPs and (2) layer silicate (= hydrated) IDPs, layer silicates occur in several anhydrous CP IDPs^{4,5}. The mineralogy, texture and volatile element enrichments of chondritic IDPs differ distinctly from carbonaceous chondrite matrix and suggest that IDPs are Solar System materials derived from a heliocentric distance $> \sim 1.8 \text{ AU}$ ^{4,7}. The Mg/[Mg+Fe] distributions in anhydrous IDPs^{5,6} are similar to this distribution in Comet Halley dust⁸ and while a link between CP IDPs and comet dust is still tenuous, I will assume that anhydrous CP IDPs are samples of cometary origin.

Traditionally, petrologists have regarded comet nuclei as static environments that preserve unmetamorphosed presolar dust for $\sim 4,550 \text{ My}$. By inference, physical models for active comet nuclei must also constrain environments that will be conducive to mineralogical activity. A recent nucleus model⁹ postulates three different dust environments: (1) porous refractory boulders cemented in (2) an ice-dust matrix and (3) a low-albedo dust mantle. The thermal history of a nucleus includes (1) internal heating (e.g. decay of Al^{26}), (2) surface heating at perihelion and (3) transient events such as devitrification of amorphous water ice and thermally activated release of stored chemical energy¹⁰. Mineralogical activity in ice-dust mixtures requires a thermal regime in excess of $\sim 200\text{K}$ for hydrocryogenic alterations to occur in interfacial water layers at dust-ice interfaces^{11,12}. The high ($\sim 330\text{K}$) average surface temperature of Comet Halley's nucleus during perihelion probably supports a thermal gradient for a sufficiently long period (~ 100 days) to allow *in situ* hydrocryogenic alterations to occur. Depending on the physical properties, similar conditions may exist in nuclei of other short-period comets during perihelion passage. For this discussion, I concentrate on perihelion heating as similar conditions may occur during trans-Earth flight (typically ~ 1250 days) in improperly curated comet nucleus samples.

COMET DUST ANALOGS. Mineralogical and structural analyses of granular units in CP IDPs show that (1) grains $< \sim 0.03 \mu\text{m}$ in size form (sub-) rounded grains, (2) larger grains form thin, sub- to euhedral platy crystals and (3) the platy crystals are regularly embedded in carbonaceous material¹³. These observations have been interpreted as due to annealing of amorphous chondritic precursor material⁶ and I conclude that unmetamorphosed dust in comets has (1) a chondritic composition and (2) is structurally amorphous⁶. A revised norm calculation¹⁴ of CP IDPs¹⁵ shows a nepheline-normative mineralogy including forsterite, feldspar [$\text{Na}/(\text{Na}+\text{Ca}) = 0.91$], FeS and chromite. Thermal annealing, or devitrification, of amorphous precursor dust produces ultrafine-grained (modal size = 0.015 μm) minerals⁶. The ultrafine grain size of minerals formed in this manner in CP IDPs will be most susceptible to aqueous alterations^{16,17}.

DEVITRIFICATION, or uncontrolled crystallisation, of amorphous material can produce a crystalline product with a wide range of chemical compositions, mineralogy and texture. In general, devitrification produces the kinetically most favourable crystalline phases rather than those involving the greatest reduction in free energy which implies the formation of solids that are structurally or chemically similar to the amorphous precursor. Factors influencing devitrification are cooling rates, presence of nucleants (e.g. transition metal ions), precursor viscosity, density of nuclei, chemical concentrations, diffusion rates, orientation and distribution of growing crystals, presence of gases or aqueous solution^{18,19}. Devitrification involves three stages (1) an induction period during which phase separation may occur, (2) (initial) rapid growth and (3) slow growth and coarsening²⁰. In the induction period, amorphous phase decomposition or crystallisation occurs via either homo- or heterogeneous nucleation at the surface of, or within, the amorphous phase¹⁸. The relative amount of phases crystallised are controlled to a large extent by the original precursor composition and the stoichiometry of the phases crystallising from the precursor¹⁸ although a non-stoichiometric phase may initially crystallise as a function of precursor composition and its previous history²¹.

HYDRATION RATES. Experimental data show that hydration rates for silicates increase as a function of (decreasing) grain size^{16,17} is used to evaluate hydration rates for ultrafine grained minerals in granular units of CP IDPs. At this point, I can only extrapolate the data to include nanometer size grains but the results dramatically show the vulnerability of ultrafine-grained silicates to aqueous alterations. For example, at 0.5 kbar and 293K serpentinisation of forsterite decreases from 0.27My (grains 50mm in diameter) to 540 years for grains 0.1 mm in diameter¹⁷. Extrapolation of this data to grains 0.015 μ m in diameter shows a reduced reaction time of 18 days while a reaction time of ~1 month is found by tentative extrapolation to 200K for these ultrafine grains. Hydration reactions involve lattice and grain boundary diffusion and it is therefore necessary to evaluate diffusion at hydrocryogenic temperatures. The compensation law is used to evaluate the effective lower limit for diffusion in silicates and glasses as a function of grain size²². I calculate that diffusion processes with activation energy less than ~85.0 kJ.mole⁻¹ will cease to operate at 200K in grains 0.015 μ m, in diameter. Examples of activation energies that meet this criterion include diffusion of Na, K, H, D and He in silicate glasses^{23,24}.

CONCLUSIONS. Unmetamorphosed comet dust is probably structurally amorphous. Thermal annealing of this dust can produce ultra fine-grained minerals and this ultrafine grain size of CP IDPs should be considered in our assessments of aqueous alterations that could affect presolar dust in comet nuclei between 200 and 400K. Devitrification and hydration may occur *in situ* in ice-dust mixtures and the mantle of active comet nuclei. Devitrification, or uncontrolled crystallisation, of amorphous precursor dust can produce a range of chemical compositions of ultrafine-grained minerals and (non-equilibrium) mineral assemblages and textures in dust contained in comet nuclei as a function of period and trajectory of orbit and number of perihelion passages (not considering internal heating). Thus, experimental data on relevant processes and reaction rates between 200 and 400K are needed in order to evaluate comet selection, penetration depth for sampling device and curation of samples for CNSRM.

REFERENCES: 1. Brownlee D.E. (1987) *Phil. Trans. R. Soc. London A* 323, 305-311; 2. Wood J.A. (1986) *ESA SP-249*, 123-131; 3. Rietmeijer F. J. M. et al. (1986) *Icarus* 65, 211-222; 4. Mackinnon I. D. R. and Rietmeijer F. J. M. (1987) *Rev. Geophys.* 25, 1527-1553; 5. Bradley J. P. (1988) *Geochim. Cosmochim. Acta* 52, 889-900; 6. Rietmeijer F. J. M. (1989) *Proc. 19th Lunar Planet. Sci. Conf.*, in press; 7. Rietmeijer F. J. M. (1988) *Chem. Geol.* 70, 33; 8. Jessberger E. K. et al. (1988) *Nature* 332, 691-695; 9. Gombosi T. I. and Houpis H. L. F. (1986) *Nature* 324, 43-44; 10. Carpenter J.M. (1987) *Nature* 330, 358; 11. Rietmeijer F. J. M. (1985) *Nature* 313, 293-294; 12. Rietmeijer F. J. M. and Mackinnon I. D. R. (1987) *ESA SP-278*, 363-367; 13. Rietmeijer F. J. M. and McKay D. S. (1986) *Lunar Planet. Sci.* 17, 710-711; 14. Rietmeijer F. J. M. (1987) *Lunar Planet. Sci.* 18, 834-835; 15. Schramm L. S. et al. (1988) *Lunar Planet. Sci.* 19, 1033-1034; 16. Wood D. J. and Walther J. V. *Science* 222, 413-415; 17. Wegner W. W. and Ernst W. G. (1983) *Am. J. Sci.* 283-A, 151-180; 18. Redwine R. H. and Conrad M. A. (1988) In: *Ceramic Microstructures* (Fulrath R. M. and Pask J. A., eds), 900-921, R. E. Krieger Publ. Co; 19. Doremus R. H. (1973) *Glass Science* Chapt. 13, Wiley Interscience; 20. Zdaniewski W. A. (1978) *J. Am. Cer. Soc.* 61, 199; 21. Orsini P. G. et al. (1975) *J. Am. Cer. Soc.* 58, 306; 22. Hart S. R. (1981) *Geochim. Cosmochim. Acta* 45, 279-291; 23. Winchell P. (1969) *High Temp. Sci.* 1, 200-215; 24. Freer R. (1981) *Contrib. Mineral. Petrol.* 76, 440-454.

This work is supported by NASA Grant NAG 9-160.

HANDLING AND ANALYSIS OF ICES IN CRYOSTATS AND GLOVE BOXES IN VIEW OF COMETARY SAMPLES K. Roessler¹⁾, G. Eich¹⁾, M. Hey¹⁾, H. Kochan²⁾, A. Oehler³⁾, A. Patnaik¹⁾, W. Schlosser⁴⁾, R. Schulz¹⁾²⁾; 1) Institut für Chemie 1 (Nuklearchemie) der Kernforschungsanlage, D-5170 Jülich 2) Institut für Raumsimulation der DFVLR, D-5000 Köln 90 3) Institut für Optoelektronik der DFVLR, D-8031 Oberpfaffenhofen 4) Astronomisches Institut der Ruhruniversität, D-4630 Bochum

Comet nucleus sample return mission and other return missions from planets and satellites need equipment for handling and analysis of icy samples at low temperatures under vacuum or protective gas. Two methods are reported here which were developed for analysis of small icy samples and which are modified at present for the larger samples in cometary matter simulation experiments (KOSI) [1,2]. They provide a base for the handling of return samples.

A conventional optical cryostat system was modified to allow for transport of samples at 5 K, ion beam irradiation, and measurement in an off-line optical spectrophotometer [3]. The new version consists of a removable window plug containing nozzles for condensation of water and volatiles onto a cold finger [4]. This plug can be removed in a vacuum system, changed against another plug (e.g. with other windows (IR, VIS, VUV) or other nozzles). While open, the samples can be treated under vacuum and cooling by manipulators (cut, removal, sample taking, irradiation with light, photons, or ions). After bringing the plug back, the samples can be moved to another site of analysis.

For handling the 30 cm diameter mineral-ice samples from the KOSI experiments an 80x80x80 cm glove box made out of plexiglass was used. The samples were kept in a liquid nitrogen bath, which was filled from the outside. A stream of dry N₂ and the evaporating gas from the bath purified the glove box from impurity gases and, in particular, H₂O, which otherwise would condense onto the samples. The gas room around the sample had finally a temperature between -50°C and -70°C, which excluded any thermal effect of ev. warm gas on the surface of the sample. Likewise the tools, e.g. for sample taking, were stored in the glove box and cooled to a reasonable working temperature (-50°C). Handling of the sample was done with thick insulated gloves or manipulators. The size of the glove box and with it the temperature gradient were sufficient to impede condensation on the outer walls.

Besides optical inspection, sample taking, drilling of boreholes, measurement of mechanical properties (Newtonmeter from ESA-ESTEC, G. Schwehm), in particular, optical spectroscopy with a field spectrometer was performed under several angles in order to determine the albedo and the surface composition (A. Oehler). Other methods of spectroscopical analysis can easily be performed inside or outside (optical beam). Another arrangement was used to determine the composition of mixed ices (minerals-H₂O-CO₂-etc.). The ices were filled inside the glove box into small tight teflon containers with valves. Upon slow heating the volatile gases evolved were caught in cylinders. Gas samples were taken and analyzed by gas chromatography.

- [1] E. Grün, H. Kochan, K. Roessler, and D. Stöffler, ESA/SP/278, 501-508 (1986)
- [2] H. Kochan, J. Benckhoff, A. Bischoff et al., Proc. 19th (1987) Lunar and Planet Sci Conf., in press (1988)
- [3] L. Pross, J. Hemmerich, and K. Roessler. Rev. Sci. Instr. 47, 353-355 (1976)
- [4] E. Armborst and K. Roessler, Report Jül-2089 (1986) 84 p.

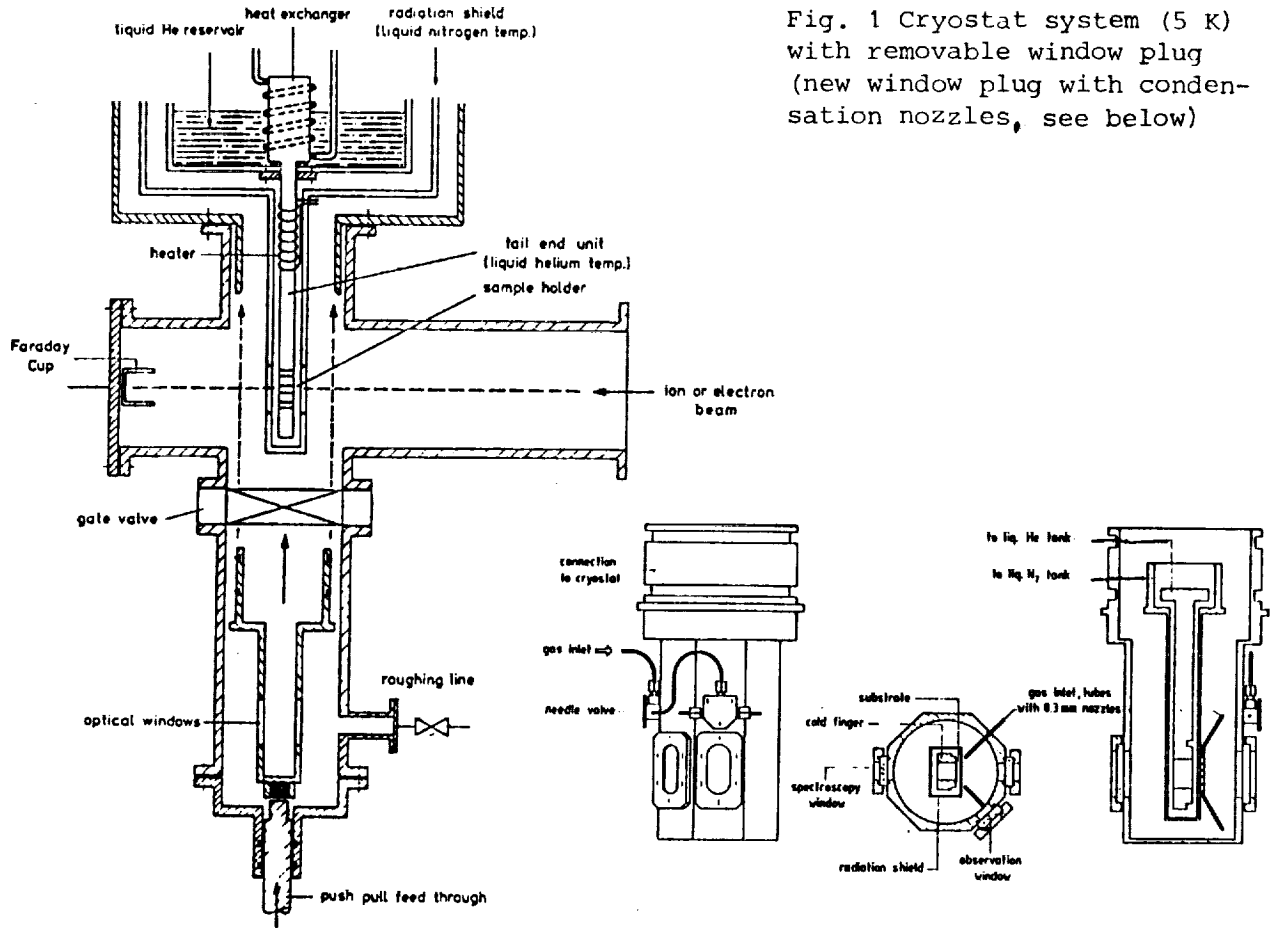

Fig. 1 Cryostat system (5 K) with removable window plug (new window plug with condensation nozzles, see below)

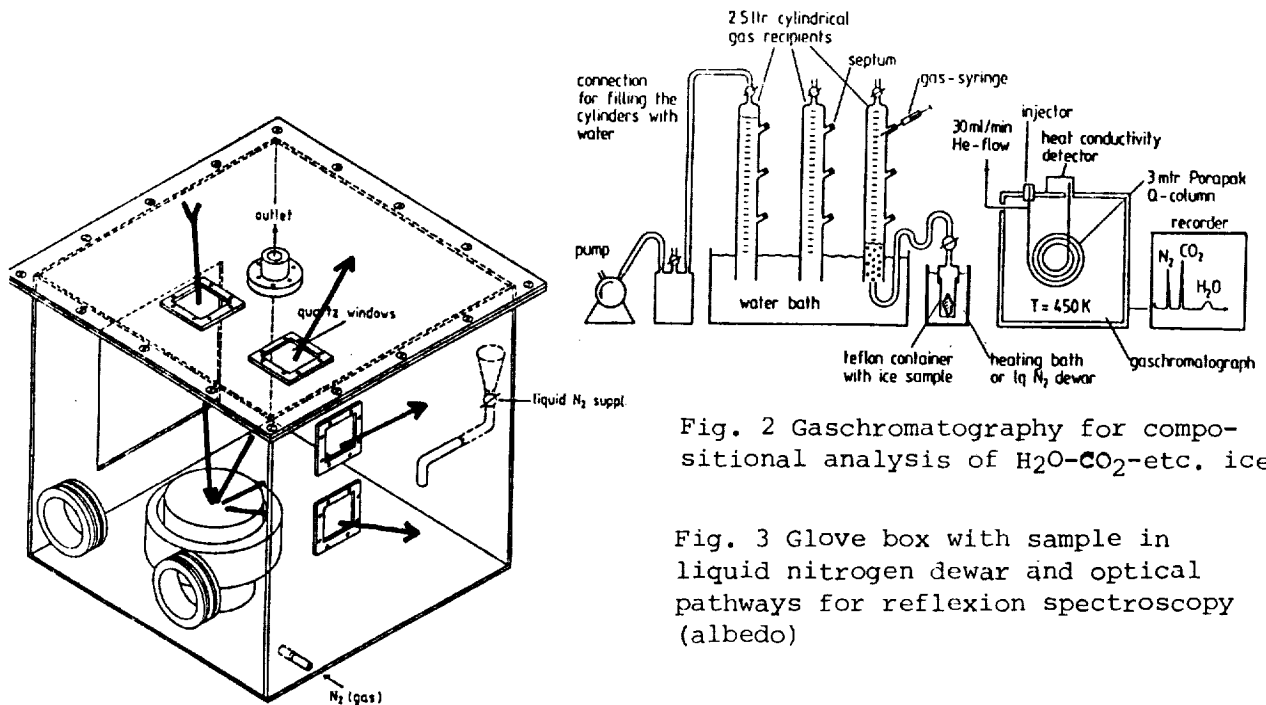

Fig. 2 Gaschromatography for compositional analysis of H₂O-CO₂-etc. ices

Fig. 3 Glove box with sample in liquid nitrogen dewar and optical pathways for reflexion spectroscopy (albedo)

TRAJECTORY-CAPTURE CELL INSTRUMENTATION FOR MEASUREMENT OF DUST PARTICLE MASS, VELOCITY AND TRAJECTORY, AND PARTICLE CAPTURE* :J.A. Simpson and A.J. Tuzzolino, Laboratory for Astrophysics and Space Research, Enrico Fermi Institute, The University of Chicago, Chicago, Illinois 60637

Our earlier development of the PVDF dust detector (1) for space missions--such as the Halley Comet Missions where the impact velocity was very high (2) as well as for missions where the impact velocity is low (3)--have been extended to include:

- a) the capability for impact position determination - i.e., x,y coordinate of impact, as illustrated in FIG. 1a (3) and;
- b) the capability for particle velocity determination using two thin PVDF sensors spaced a given distance apart - i.e., by time-of-flight (4,5).

Our recent dust accelerator calibrations have shown that for two thin [$6\mu\text{m}$ thick] PVDF sensors in such an arrangement, particle fragmentation effects are not severe for particles having diameter $> \sim 10\mu\text{m}$ and velocities in the range $\sim 2\text{-}12\text{ km/s}$. Thus, following particle penetration of two thin PVDF sensors, sufficient mass [in the form of one or a few fragments] is available for capture by a suitable capture cell device for analysis (4,5). These developments have led to space flight instrumentation for recovery-type missions illustrated in FIG. 1b and c, which will measure the masses [sizes], fluxes and trajectories of incoming dust particles and will capture the dust material in a form suitable for later Earth-based laboratory measurements. These laboratory measurements would determine the elemental, isotopic and mineralogical properties of the captured dust and relate these to possible sources of the dust material [i.e., comets, asteroids], using the trajectory information. For each incident particle, the instrumentation will:

- a) measure signal sizes from the upper and lower plane sensors penetrated;
- b) determine which sensors are penetrated;
- c) measure time-of-flight for the penetrated sensors, and;
- d) determine the capture cell containing particle residue.

If each sensor is an x,y sensor, particle trajectory is determined with an angular accuracy of $\sim 1^\circ$. If each sensor is non-position sensing, trajectories are measured with a mean accuracy of $\sim 5^\circ$. The instrumentation described here has the unique advantages of providing both orbital characteristics and physical and chemical properties--as well as possible origin--of incoming dust.

- (1) Simpson, J.A. and Tuzzolino, A.J. (1985) *Nucl. Instr. & Meth.*, A236, p. 187.
- (2) Perkins, M.A., Simpson, J.A. and Tuzzolino, A.J. (1985) *Nucl. Instr. & Meth.*, A239, p. 310.
- (3) Simpson, J.A. (An invited paper presented at the Workshop on the Multi-comet Missions, NASA/Goddard Space Flight Center, Sept. 17, 1986), EFI Preprint No. 86-81.
- (4) Simpson, J.A. and Tuzzolino, A.J., to be submitted for publication, EFI Preprint No. 87-106.
- (5) Simpson, J.A. and Tuzzolino, A.J., to be submitted for publication, EFI Preprint No. 88-69.

*This research was supported in part by NASA Contract NAS W-4196.

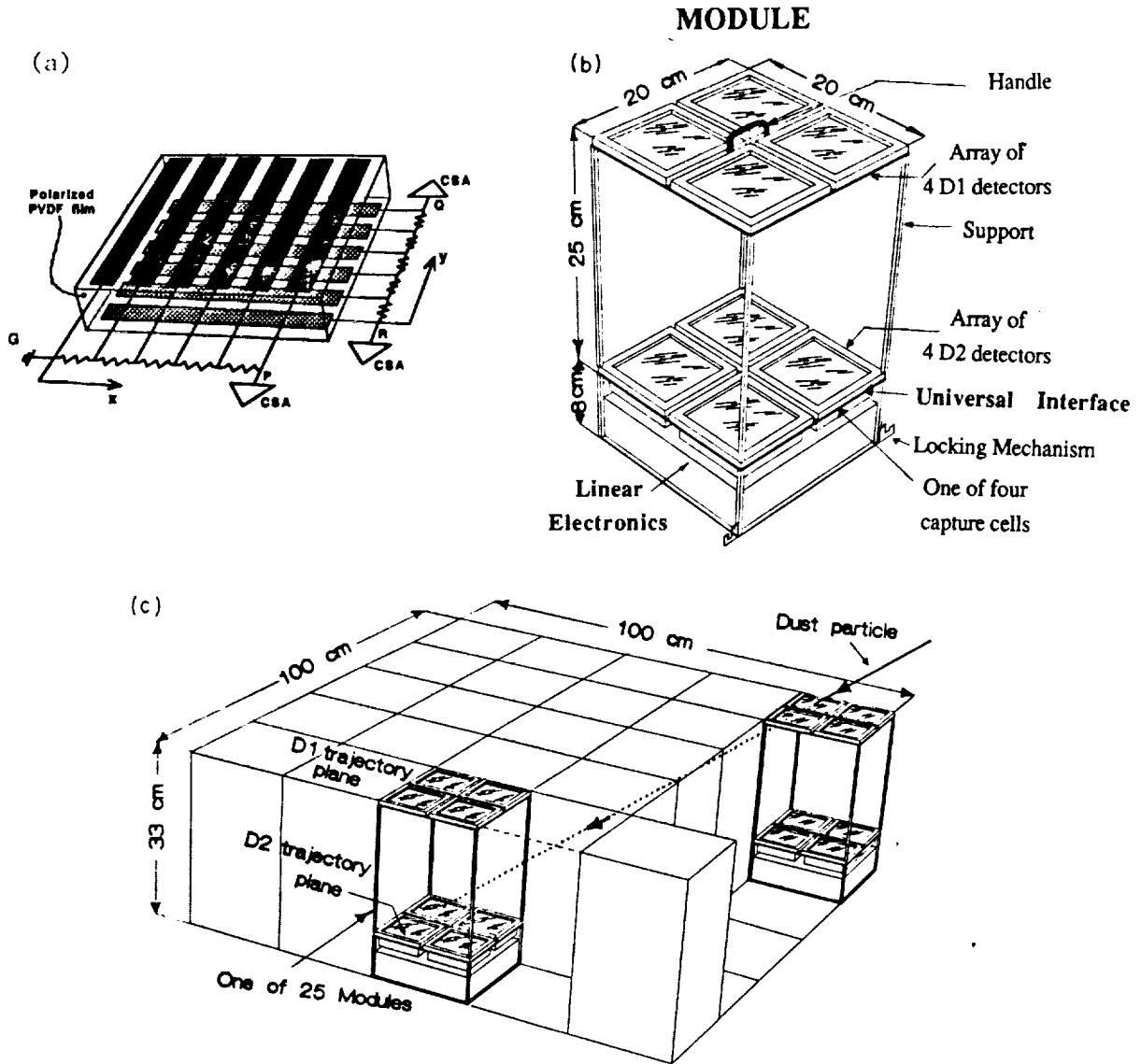

Fig. 1 (a) Two-dimensional position sensing PVDF detector (x,y detector). Upon dust particle impact, P, Q, R signals are generated. The x coordinate of impact is determined from the ratio $P/(Q+R)$ and the y coordinate from the ratio $Q/(Q+R)$. (b) Trajectory-capture cell MODULE. The four D1 and four D2 PVDF detectors are either x,y detectors, or may be non-position-sensing. The capture cells have a depth ~ 1 cm. (c) Basic instrument consisting of 25 identical MODULES. Trajectories are determined for angles of incidence up to ~ 78°. The geometry factor for trajectory measurement is 0.37 m² ster.

THERMAL HISTORIES OF THE SAMPLES OF TWO KOSI COMET NUCLEUS SIMULATION EXPERIMENTS; T. Spohn¹, J. Benkhoff¹, J. Klinger^{2,4}, E. Grün³, and H. Kochan²; 1) Institut für Planetologie, Westfälische Wilhelms-Universität, 4400 Münster 2) Deutsche Forschungs- und Versuchsanstalt für Luft- und Raumfahrt e.V., 5000 Köln 90 3) Max Planck Institut für Kernphysik, 6900 Heidelberg 4) Laboratoire de Glaciologie et de Geophysique de l' Environnement, St. Martin d' Hères (France)

Temperatures recorded during two KOSI comet nucleus simulation experiments strongly suggest that heat transport by vapor flow into the interior of the sample is very important.

Two comet nucleus simulation experiments have been done by the KOSI team in a big space simulator at the Deutsche Forschungs- und Versuchsanstalt für Luft- und Raumfahrt (DFVLR) in Köln/Porz. Detailed reports on the experiments have been given by Grün *et al.*(1) and by Kochan *et al.*(2,3) Here, we will report on the thermal evolution of the sample during insolation and we will discuss the results of simplified thermal evolution calculations.

The space simulator used at DFVLR/Köln is basically a vacuumized cylinder of 4.8m length and 2.4m diameter. The interior is cooled by liquid nitrogen and the interior pressure is kept constant at 10^{-4} Pa. The two samples were 30cm in diameter and 12 and 15cm, respectively, in thickness. The first experiment, henceforth referred to as KOSI-1, was done in the spring of 1987 and the second, KOSI-2, was done in the spring of 1988. The dust to water ratio was 1/10 for both experiments and the dust component was a mixture of clay minerals, with 0.083% by weight carbon added for KOSI-2. The admixture of carbon resulted in an albedo of 0.06. The samples consisted of frozen droplets of mostly submillimeter size; the density was about 600kg/m^3 and the porosity was estimated to be 0.4. The samples were insolated by Xenon lamps for 2 hours at 714W/m^2 followed by 10 hours at 1000W/m^2 during KOSI-1 and for 16.5 hours at 1360W/m^2 during KOSI-2. During both experiments, the bottom of the sample was cooled by liquid nitrogen to enforce a constant temperature of about 100K. Following the period of insolation at a constant rate during KOSI-2, there was a second period of insolation at a varying rate which, however, is not of interest for the present purpose. A layer of about 3cm thickness sublimated during KOSI-1 while mass spectrometry suggested a total mass loss of about 400g during KOSI-2. Near surface layers of 5cm and 4cm thickness of metamorphosed or annealed ice were observed while the samples were analyzed after the experiments. The texture of the metamorphosed ice differed considerably from that of the original sample. The metamorphosed ice was mechanically hard but still porous while the original sample was a loose agglomerate of spherules.

The temperature recordings of KOSI-2 are shown as an example in fig. 1. The most striking feature of the temperature profiles is their convex shape attained after 5 to 10 hours into the experiment. The initial temperature profile increased from 100K at the backplate to about 140K at the surface. After about five hours in both experiments the thermocouple next to the surface was at a temperature of about 200K, close to the sublimation temperature of 205K at the chamber pressure. A close to equilibrium temperature profile was reached after about 9 hours for KOSI-1 and 15 hours for KOSI-2. Following this time, only small increases in temperature were recorded.

The observed thermal histories cannot be explained by a simple model with heat transferred by heat conduction at a constant conductivity. In order to explain the observed thermal histories we considered a coupled heat and mass transfer problem. The porous ice matrix was assumed to have a constant thermal conductivity and to be in thermal equilibrium with vapor in the pores,

the internal pressure being the vapor pressure. The vapor was modelled as an ideal gas because, at the temperatures relevant to our problem, the mean free path length of the vapor molecules is large in comparison with the pore dimensions. The heat capacity at constant volume per unit mass of the two phase mixture was also assumed constant. The vapor was allowed to flow and transfer heat in response to an internal pressure gradient.

In fig. 1 we show the results of a simplified model calculation for which we have *a priori* assumed the shape of the vapor velocity profile. We have fitted the calculated temperature profiles to the measured profiles by adjusting a suitably defined Peclet number, a dimensionless insolation parameter, and a Stefan number. We found that about 60% of the insolation rate is transferred into the interior of the sample via the vapor. In addition, we found an apparent thermal diffusivity of the ice matrix of $(2 \pm 1 \times 10^{-8} m^2 s^{-1})$.

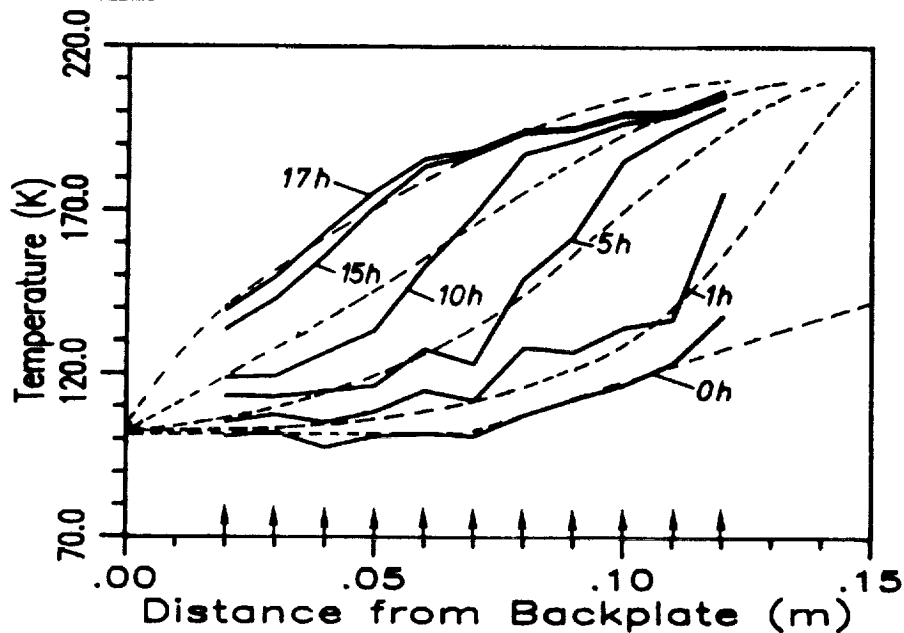

Fig. 1. Temperature profiles recorded during the KOSI-2 experiment (fat lines) and calculated from a simple thermal model (broken lines) at various times after the start of insolation. The location of the thermocouples is indicated by arrows.

REFERENCES

1. E. Grün, H. Kochan, K. Roessler, and D. Stöffler, *ESA-SP/278*, 501-508 (1987)
2. H. Kochan, J. Benkhoff, A. Bischoff, H. Fechtig, B. Feuerbacher, E. Grün, F. Joó, J. Klinger, H. Kohl, D. Krankowsky, K. Roessler, W. Seboldt, K. Thiel, G. Schwehm, and U. Weishaupt, *Proc. 19th Lunar and Planet. Sci. Conf.*, in press (1988)
3. H. Kochan, B. Feuerbacher, F. Joó, J. Klinger, W. Seboldt, A. Bischoff, H. Düren, D. Stöffler, T. Spohn, H. Fechtig, E. Grün, H. Kohl, D. Krankowsky, K. Roessler, K. Thiel, G. Schwehm, and U. Weishaupt, *Adv. Space Res.*, in press (1988)

ANALYSIS OF PARTICULATES OF COMET NUCLEUS SAMPLES; POSSIBLE USE OF OLIVINE AS INDICATOR PHASE. I. M. Steele, Dept. of Geophysical Sciences, University of Chicago, 5734 S. Ellis Ave., Chicago, IL 60637.

The electron microprobe is a proven instrument for particulate analysis and modifications are possible for *in situ* analysis of particulates in ice at temperatures near that of liquid nitrogen. Present sample requirements allow for polished samples with 0.25 x 0.25 dimensions to be maintained in the sample chamber of a modern electron probe (CAMECA SX-50) at a temperature of -150°C ; larger samples are possible but at higher temperatures as determined by thermal conductivity. The major problem is transport and insertion of samples into the instrument through vacuum interlocks. The manufacturer of the above microprobe has designed on paper an exchange mechanism to allow storage and transport of samples previously prepared for their sample holder which attaches to their instrument allowing extraction and insertion of samples while maintaining -150°C temperature. An important test will be the capability of preparing polished surfaces of an ice-particulate sample without loss of particles and at low temperatures. While thin sections of water ice are routine, these are not examined for particulate material and are prepared at temperatures easily obtained in room-size volumes. Anticipated problems include rounding of small grains in the relatively soft ice matrix and the technical problem of dry polishing.

Less constraining is the analysis of particles recovered from ice; those larger than about 10 microns can be handled individually or as a group permitting preparation of polished grain mounts. Below this size, analysis techniques for unpolished samples must be used. In general the larger the grain, the greater the current and kV of the primary electron beam permitting detection of minor and trace elements. Typical examples of grain size, analysis conditions and expected results can be obtained from extensive analysis of forsterite grains in meteorites and other extraterrestrial samples including deep sea and stratospheric particles and Greenland lake sediment:

- 1) Polished large grains (>20 microns): 25 kV, 100nA; Mg, Al, Si, P, Ca, Sc, Ti, V, Cr, Mn, Fe, Ni; detection limits 30-70ppm.
- 2) Polished small grains (10-20 microns): 15 kV, 25nA; Mg, Al, Si, Ca, Cr, Mn, Fe, Ni; detection limits 100-200ppm.
- 3) Unpolished grains (<10 microns): 15 kV, 25 nA; Mg, Si, Ca, Cr, Mn, Fe, Ni; detection limits >150ppm with errors greatest for light elements with high absorption.

The above generalized analytical limits can be extended in many cases by parallel use of the x-ray microprobe utilizing synchrotron radiation.

The above data for olivine are based on extensive analyses in all types of olivine-bearing extraterrestrial material (1,2). Because this phase is possibly the most common phase, shows relatively simple crystallography, and is the most widespread high-temperature phase, its use for comparison among the different sample types has proved fruitful. For example, the levels and trends of minor elements allows the recognition based on single grain analyses of olivine in the following meteorite groups: 1) C3-UOC (unequilibrated ordinary chondrites); 2) C2; 3) C3. Manganese, for example, appears to show a systematically higher level in olivines from the C1 meteorites and the Cr-Fe variation is clearly different for C2 and C3-UOC olivines. Although extensive analyses have not been made, the surviving olivines in the deep sea particles are chemically similar to C2 olivines (3); data are too few to derive analogous relations for stratospheric particles and Greenland lake sediment but the samples

are available.

Assuming that olivine is a constituent of cometary particulate material (4,5), its chemical relations to the known olivine-meteorite associations would be a powerful constraint for relating the earliest phases within all these materials.

Acknowledgements: Financial support was derived from NASA NAG 9-47 (J.V. Smith) and instrumental support through NSF EAR-8415791 and NSF EAR-8608299.

References: (1) Steele, I.M., Smith, J.V. and Brownlee, D.E. (1985) *Nature* **313**, 297-299. (2) Steele, I.M. (1986) *Geochim. Cosmochim. Acta* **50**, 1379-1395. (3) Steele, I.M., Smith, J.V. and Skirius, C. (1985) *Nature* **313**, 294-297. (4) Christoffersen, R. and Buseck, P.R. (1986) *Earth Planet. Sci. Letts.* **78**, 53-66. (5) Bradley, J.P. and Brownlee, D.E. (1986) *Science* **231**, 1542-1544.

THE NATURE OF COMETARY MATERIALS, James Stephens, Jet Propulsion Laboratory, Pasadena, CA

Because cometary surfaces are likely to be far colder and of a different composition than other planetary surfaces with which we have experience, there are some new considerations that must be examined in regards to placing instrumented packages or sample return devices on their surfaces. The qualitative analysis of the problem of attaching hardware to a comet and not being ejected back into space can be divided into two parts.

The first problem is to pierce the mantle and obtain access to the icy core. Drilling through the mantle requires that the drilling forces be reacted. Reacting such forces probably requires attachment to the icy core below. Therefore, some kinetic impact piercing device is likely to be required as the first act of attachment. This piercing device may ricochet off of the mantle if it cannot be directed approximately perpendicular to the impact surface. The local surface may be closer to vertical than to horizontal because solar heat focusing, fluid dynamic channeling and electrostatic filament forming forces will likely prevail over the low comet gravity to form very grotesque surface topography. Furthermore, if the mantle that covers the icy core has mineral particles that are bonded together by a tar-like substance and if the surface tension forces of this "tar" prevail then the mantle may shrivel to form an "asphalt" like, brittle, high density, high strength material. In addition, new cometary mantles may be formed from the thermally stress-fractured remnants of earlier mantles.

The second problem for a piercing device to overcome is the force produced by the impact kinetic energy that tries to eject the piercing device back into space. The mantle and icy core can absorb some of the impact kinetic energy in the form of fracture formation and friction energy. The energy that is not absorbed in these two ways is stored by the core as elastic deformation of the mantle and icy core. This elastic deformation energy is returned to the piercing device and the fragmented mantle and core material that surrounds it after the piercing device comes to zero velocity. The elastic deformation rebound force is assisted by the pressure force of the gas that is formed by the previously mentioned fracture formation and friction energy. Much of the fracture formation and friction energy is converted into heat that is ultimately converted into gas because the icy core is in thermodynamic equilibrium with its under-mantle environment. An additional source of gas is supplied by the new equilibrium that the core must achieve when the conductance through the mantle is increased by the additional venting of the mantle by the piercing device.

The drill or penetrator must develop hold-down forces that can overcome the elastic deformation rebound force and the pressure force of the gas. Hold-down forces that depend upon friction between the piercing device and the icy core may be insignificant because a gas bearing may form at the contact between the piercing device and the icy core. Hold-down forces that depend upon cohesion between the piercing device and the icy core are likely to be insignificant because there are no liquids that are likely to form at the interface and bond the piercing device to the core. Even if the icy core can rebound and clamp the piercing device in the crater, the friction forces and the cohesive forces remain small. Hold-down forces that depend upon fixed or deployed barbs are insignificant because they will shatter the core material during entry as does the piercing device and it is unlikely that the material that they engage will still be attached to the core. Even if anchoring devices could be deployed horizontally below the surface of the unfractured icy core, the hold-down force might be as little as the gravity force of the pieces of the core that may be fractured by the deployment forces of the barbs. Subsurface wedging forces may be very large in low porosity and brittle substances and the resulting cracks may extend to the surface.

It is concluded that because the cometary materials are almost certainly brittle and the icy core is likely to be self lubricating, the elastic rebound and gas pressure expulsion forces must be counteracted by forces greater than those that may be provided by a piercing device or its capture devices (barbs).

METHODS FOR THE MINERALOGICAL AND TEXTURAL ANALYSIS OF COMET NUCLEUS SAMPLES; D. Stöffler, H. Düren and J. Knöfker, Institut für Planetologie, Universität Münster, D-4400 Münster, Germany.

This abstract attempts to review the objectives and instrumental requirements of a petrographic analysis of porous comet nucleus material. It is organized in four main sections which will deal with (I) the objectives of the petrographic analysis of cometary material, (II) the assumptions about its composition and texture, (III) the available techniques for the microscopic analysis of comet analogue material, and (IV) new techniques required for the petrographic investigation of natural and artificial comet nucleus samples.

I. Objectives of the petrographic analysis of returned comet nucleus material

In the context of the Comet Nucleus Sample Return Mission ROSETTA (1) the petrographic laboratory analysis of returned samples under the conditions of the parent comet nucleus is fundamental for any further chemical, isotopic, and physical analysis of the bulk sample and its constituent phases. It is also a prerequisite for the intelligent allocation of sample aliquots to specialized investigators in sophisticated terrestrial laboratories. The petrographic analysis of cometary material must be capable of characterizing various properties of the bulk samples quantitatively. It must also provide ways of identifying the constituent phases and composite textural subunits of the sample. For the bulk sample one needs to know (1) the type and abundance of the constituents (inorganic minerals, ices and clathrates, carbonaceous material, and aggregations of these considered as textural subunits) and (2) the textural properties such as the grain size distribution, morphology and intergrowth characteristics of the constituents; anisotropy of distribution and orientation of the constituents; porosity. The constituent phases must be characterized by their chemical composition and structural state.

II. Assumptions about the composition and texture of comet nucleus samples

The application and development of instrumental techniques which will meet the objectives defined above, requires a model of the composition and texture of comet nucleus material. Information which is relevant for such a model, can be obtained from direct observations of comets and interstellar dust, from the study of primitive solar system material (e.g. cosmic dust and primitive meteorites), from the theory of grain formation in solar and stellar nebulae and from accretion and evolution models of comets (2, 3, 4). Our best estimate of the expected main constituents of a comet nucleus are the following: (a) ice crystals including clathrates (H_2O , CO_2 , CO , CH_4 , NH_3 etc.), (b) inorganic minerals such as silicates (olivine, pyroxene, sheet silicates), oxides, sulfides, carbides, metal and others, (c) carbonaceous matter ranging from amorphous and crystalline carbon to hydrocarbons of variable composition and degree of polymerisation, (d) "rock-like" aggregates of inorganic minerals and carbonaceous matter, (e) aggregates of ices and all types of refractory constituents (b), (c), (d) and (e).

One can expect a variety of textural characteristics of the samples. These include coating of inorganic phases by carbonaceous material, porous to fluffy aggregation of ices and refractories, small grain size of the individual crystals ($< 10 \mu m$, with most grains $< 1 \mu m$), large variation of the size of aggregates (possibly from μm to dm or m), and preferred orientation and anisotropic distribution of the constituents (layering, accretion textures etc.).

III. Presently available techniques for the microscopic analysis of porous ice-mineral mixtures

Methods for the microscopic analysis of weakly coherent snow and solid ice in polished sections and thin sections have been developed by workers in the snow, ice, and avalanche research areas since the late 1930's (e.g. (5), (6) and papers in (7)). The basic principle of the preparation of polished sections and thin sections is to impregnate the porous snow sample with an organic liquid having a freezing point below the freezing point of H_2O and to crystallize this liquid at lower temperatures. This allows the sample to be cut and thin sections to be produced by a microtome technique. A stereometric analysis can then be made by an automated image analysis of micrographs obtained by any type of microscope in reflected or transmitted light (7).

This method yields the complete set of modal and textural data discussed in section II. The most advanced information about the three-dimensional structure of the sample results from the stereometric analysis of serial cuts (7) which are taken at increasing depths of the sample (with a constant spacing of some tens of μm or less).

The microtome technique applied by snow researchers can be used for comet nucleus analogue materials only if the enclosed refractory minerals have a Mohs hardness similar to that of ice ($\sim 1.5 - 2$), e.g. for mixtures of ice or snow and sheet silicates. We have made first successful tests to prepare thin sections of ice-olivine and snow-olivine-smectite-carbon mixtures with a special microtome equipped by a rotating double-diamond milling head.

The preparation of thin sections and polished sections of synthetic cometary material has been performed so far in a low temperature laboratory with two rooms kept at different temperatures (~ 268 K and ~ 258 K). The sections can be studied either with microscopes used inside the cold laboratory at temperatures as low as ~ 235 K or with microscopes equipped with cryostat cells which easily allow temperatures as low as ~ 80 K (liquid nitrogen). However, a preparation method for microscopic sections at comet nucleus temperatures is not yet available.

IV. Required new techniques for the petrographic analysis of natural and artificial comet nucleus samples

The petrographic characterization of returned comet nucleus samples will be an integral part of a curatorial facility required for handling, preliminary examination, and distribution of such samples to specialized investigators. A possible curatorial system is visualized in a simplified and schematic flow diagram (Fig. 1) which may illustrate the needs for specific techniques. Some major instrumental developments for the petrographic analysis are tentatively summarized as follows: (a) Handling of samples under cometary conditions (vacuum; 100 - 200 K temperature range; clean chemical conditions; preservation of texture) by a system a cryostat locks and cabinets with remote manipulators, (b) preparation techniques for consolidating, cutting, thin sectioning and polishing comet nucleus samples at temperatures < 230 K, (c) techniques for the non-destructive textural and modal characterization ("tomographic" methods), (d) techniques for the remotely operated separation of the constituents of a bulk cometary sample.

REFERENCES: (1) ROSETTA, The comet Nucleus Sample Return Mission, Report of the Joint ESA/NASA Science Definition Team Space Science Department of ESA, ESTEC, Noordwijk, The Netherlands, SCI (87) 3, 1987. (2) Wilkening L.L. (ed.) (1983) Comets, The University of Arizona Press, Tucson, Arizona. (3) Grewing M., Praderie F., and Reinhard R. (eds.) (1988) Exploration of Halley's Comet, Spinger Verlag, Berlin. (4) The Comet Nucleus Sample Return Mission, Proceed. ESA Workshop, Canterbury, U.K., 15-17 July 1986, ESA SP-249, ESTEC, Noordwijk, The Netherlands, 1986. (5) Bader H., Haefeli R., Bucher, E., Neher J., Eckel O., Thams C., and Niggli P. (1939) Der Schnee und seine Metamorphose (Snow and its Metamorphism), Transl. 14, US Snow, Ice, Permafrost Res. Establ. Wilmette, IL. (7) Avalanche Formations, Movement and Effects (1987) Proceed. Davos Symposium 1986, IAHS Publ. No. 162, 1987. (6) Good W. (1982) Z. Gletscherk. Glazialgeol. 18, p. 53-64.

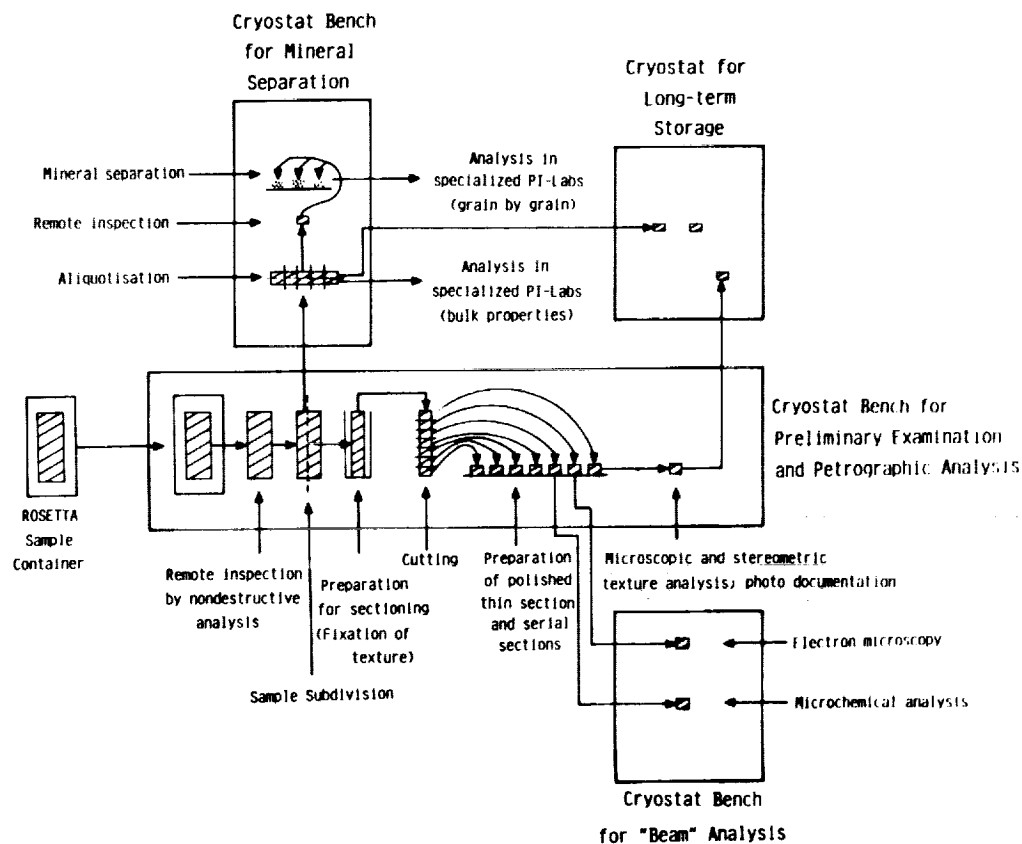

Fig. 1. Flow diagram for the curation and petrographic characterization of comet nucleus samples

NON-DESTRUCTIVE TRACE ELEMENT MICROANALYSIS OF AS-RECEIVED COMETARY NUCLEUS SAMPLES USING SYNCHROTRON X-RAY FLUORESCENCE; S. R. Sutton, Department of the Geophysical Sciences, The University of Chicago, Chicago, IL 60637 and Department of Applied Science, Brookhaven National Laboratory, Upton, NY 11973.

The Synchrotron X-ray Fluorescence (SXRF) Microprobe at the National Synchrotron Light Source (NSLS), Brookhaven National Laboratory, will be an excellent instrument for non-destructive trace element analyses of cometary nucleus samples [1,2]. Analyses of individual, cometary mineral grains are discussed in an accompanying abstract by Flynn and Sutton and will complement currently active research on micrometeorites collected from the stratosphere [3]. Trace element analyses of *as-received* cometary nucleus material will also be possible with this technique. Bulk analyses of relatively volatile elements will be important in establishing comet formation conditions. However, as demonstrated for meteorites, microanalyses of individual phases in their petrographic context are crucial in defining the histories of particular components in unequilibrated specimens. Perhaps most informative in comparing cometary material with meteorites will be the halogens and trace metals. In-situ, high spatial resolution microanalyses will be essential in establishing host phases for these elements and identifying terrestrial (collection/processing) overprints.

The present SXRF microprobe is a simple, yet powerful, instrument in which specimens are excited with filtered, continuum synchrotron radiation from a bending magnet on a 2.5 GeV electron storage ring [4,5]. X-ray beams down to 20 micrometers are produced with a continuously adjustable collimator. X-ray spectra are obtained in air with an energy dispersive Si(Li) detector. Detection limits are near 1 ppm for virtually all elements above silicon using either K or L transitions. The microprobe has been extensively applied to problems in the earth, biological and materials sciences [6,7].

Intense, high energy x-ray excitation results in minimal energy deposition, unlike charged particle techniques employed by electron, proton, and ion microprobes. The NSLS x-ray bending magnets emit about 2×10^{11} photons/sec between 3 and 30 keV into a 100 μm spot (200 mA at 20 m from the source after 100 μm Al filtering). A 100 μm thick, ice/silicate aggregate will absorb only a few percent of these photons resulting in a total deposition rate of about 10^{-5} cal/sec. The corresponding power density is 10^{-10} W/ μm^3 compared to 10^{-4} W/ μm^3 for an electron microprobe (10 kV and 10 nA). Such a sample will have an effective thermal conductivity of about 10^{-3} cal sec $^{-1}$ cm $^{-1}$ K $^{-1}$ and can lose energy conductively at a rate ten times greater than this deposition rate. Experiments on live isolated biological cells have demonstrated the non-destructive nature of this technique [7].

A refrigerated cell will be constructed to permit analyses at low temperatures. The cell will consist essentially of an air tight housing with a cold stage. Kapton windows will be used to allow the incident synchrotron beam to enter the cell and fluorescent x-rays to exit it. The cell will be either under vacuum or continuous purge by ultrapure helium during analyses.

Several improvements of the NSLS microprobe will be made prior to the cometary nucleus sample return mission that will greatly enhance the sensitivity of the technique. First, a focusing mirror will increase the photon flux at the specimen about 1000-fold. Second, a monochromator will allow selective elemental excitation. Third, a wavelength dispersive detector will improve energy resolution. In addition, advanced synchrotron sources will come on-line. A superconducting wiggler insertion device will be commissioned at NSLS during 1989 offering more intensity and higher energy x-rays than the bending magnets. The availability of high flux at x-ray energies above 50 keV will allow efficient K excitation of high atomic number elements such as REE and platinum group elements. A major advance will occur in 1995 with the commissioning of the Advance Photon Source at Argonne National Laboratory [8]. The low emittance, high energy undulators on this

positron storage ring will be ideal for an x-ray microprobe in the 5-40 keV range with micrometer resolution and better than 100 ppb sensitivity [9].

Acknowledgments: Development of the X-ray Microprobe beam line at BNL is supported by DoE, Chemical Sciences, DE-AC02-76CH00016, NASA NAG9-106 and NSF EAR-8618346.

References: [1] R. D. Giaque, A. C. Thompson, J. H. Underwood, Y. Wu, K. W. Jones, and M. L. Rivers (1987) Measurement of femtogram quantities of trace elements using an x-ray microprobe. *Anal. Chem.* 60, 855-8. [2] K. W. Jones, W. M. Kwiatek, B. M. Gordon, A. L. Hanson, M. L. Rivers, S. R. Sutton, A. C. Thompson, J. H. Underwood, R. D. Giaque, and Y. Wu (1987) X-ray microscopy using collimated and focussed synchrotron radiation. In *Advances in X-Ray Analysis*, 31, 59-68. [3] S. R. Sutton and G. J. Flynn (1988) Stratospheric Particles: Synchrotron X-ray Fluorescence Determination of Trace Element Contents. *Proceedings of the 18th Lunar and Planetary Science Conference*, 607-614. [4] B. M. Gordon, A. L. Hanson, K. W. Jones, W. M. Kwiatek, G. J. Long, J. G. Pounds, G. Schidlovsky, P. Spanne, M. L. Rivers, S. R. Sutton, and J. V. Smith (1987) An x-ray microprobe beam line for trace element analysis. In "X-Ray Microscopy II", 56, 276-9. [5] A. L. Hanson, K. W. Jones, B. M. Gordon, J. G. Pounds, W. M. Kwiatek, M. L. Rivers, G. Schidlovsky, and S. R. Sutton (1987) Trace Element Measurements using Synchrotron Radiation. *Nucl. Instrum. Methods*, B24/25, 400-404. [6] S. R. Sutton, M. L. Rivers, and J. V. Smith (1987) Advances in geochemistry and cosmochemistry: trace element microdistributions with the synchrotron x-ray fluorescence microprobe. In "X-Ray Microscopy II", 56, 438-41. [7] K. W. Jones and J. G. Pounds (1987) Role of nuclear analytical probe techniques in biological trace element research. *Biol. Trace Element Res.* 12, 3-16. [8] M. L. Rivers (1988) Characteristics of the Advanced Photon Source and comparison with existing synchrotron facilities. In "Synchrotron X-ray Sources and New Opportunities in the Earth Sciences", Argonne National Laboratory Technical Report ANL/APS-TM-3, 5-22. [9] S. R. Sutton, M. L. Rivers, K. W. Jones and J. V. Smith (1988) X-ray Fluorescence Microprobe Analysis, In "Synchrotron X-ray Sources and New Opportunities in the Earth Sciences", Argonne National Laboratory Technical Report ANL/APS-TM-3, 93-112.

MECHANICAL AND SEM ANALYSIS OF ARTIFICIAL COMET NUCLEUS SAMPLES

K. Thiel¹, H. Kochan², K. Roessler³, E. Grün⁴, G. Schwehm⁵, H. Hellmann², P. Hsiung³, G. Kölzer¹.

¹Nuklearchemie, Universität Köln, D-5000 Köln, F.R. Germany

²Institut für Raumsimulation, DFVLR WB-RS, P.O. Box 90 50 58, D-5000 Köln, F.R. Germany

³Institut für Chemie, KFA, D-5170 Jülich, F.R. Germany

⁴Max-Planck-Institut für Kernphysik, D-6900 Heidelberg, F.R. Germany

⁵European Space Agency - ESTEC, NL-2200 Noordwijk, The Netherlands

As already reported in Ref.(1), since 1987 experiments dealing with comet nucleus phenomena are being carried out in the DFVLR simulation chambers. The main objective of these experiments is a better understanding of thermal behaviour, surface phenomena and especially the gas dust interaction.

As a function of different sample compositions and exposure to solar irradiation (Xenon-bulbs) crusts of different hardness and thickness were measured. The measuring device consists of a motor driven pressure foot (5 mm diameter), which is pressed into the sample. The applied compressive force is electronically monitored. Figure 1 shows typical stress distributions of an unirradiated and an irradiated sample. Normally the exposure time varies in the range of 2-4 hours with a solar irradiation intensity between 1 and 2.5 solar constants.

During one experiment in the big Space Simulator with a large mineral-ice sample of 30 cm diameter a penetrator was motor driven forced into a dummy target. After the experiment the irradiated sample was submitted to the same procedure. In the last case the formation of a loose dust mantle and a solid crust of 3-5 cm thickness below the surface was indicated by a relatively slow increase of the compressive force at the beginning and a steep increase when the crust was reached. After the penetration of the crust the compressive force dropped markedly.

At the end of the simulation experiment when the chamber was opened the sample was transferred into a liquid nitrogen bath to keep the sample at low temperature. To prevent freezing out of air humidity on the sample this liquid nitrogen bath was kept in a dry N₂-flooded glove box.

The structure of the crust and dust residuals is investigated by SEM-techniques. This was found to be strongly dependent on the mineral composition of the dust admixture in the artificial comet. Mainly phyllo- and neo-silicates (kaolinite, montmorillonite, olivine) are used with a maximum fraction of 10 % in 90 % water ice. Recent experiments include also CO₂-ice in concentrations around 10 %.

The SEM-investigations show that the microstructure of the residuals is dominated by the sample preparation method (see Ref.(1)). High admixtures of phyllosilicates result in millimeter sized spherules of high regularity. Increasing concentrations of neosilicate lead to dust residuals similar to Brownlee particles. High resolution video records of the sample surface during the irradiation indicates that the dust emission mechanism is strongly related to the consistency of the uppermost surface layer.

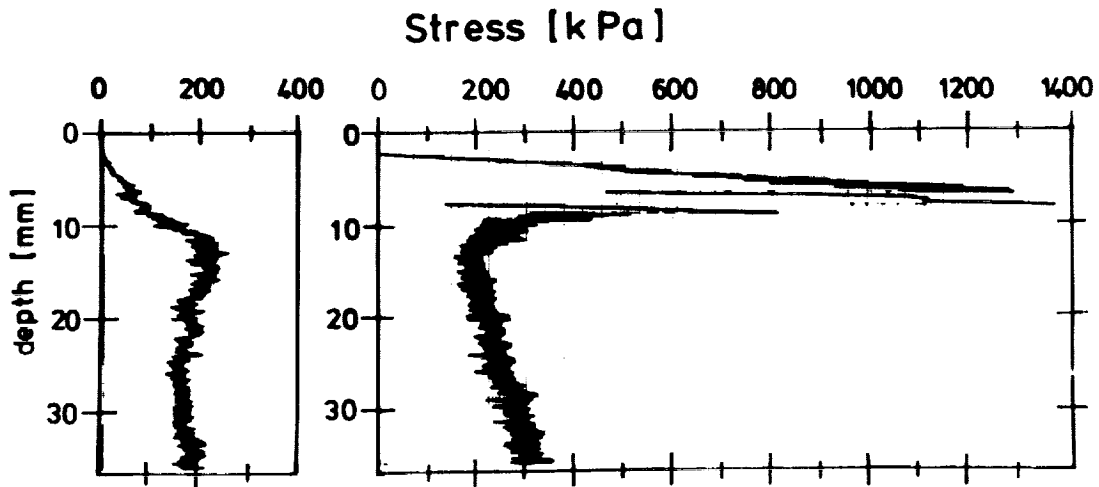

Fig.1 Stress-depth profiles of an unirradiated (left) and an irradiated (right) model comet.

Reference

H. Kochan, J. Benkhoff, A. Bischoff, H. Fechtig, B. Feuerbacher, E. Grün, F. Joó, J. Klinger, H. Kohl, D. Krankowsky, K. Roessler, W. Seboldt, K. Thiel, G. Schwehm, and U. Weishaupt, Proc. 19th Lunar and Planet. Sci. Conf., in press (1988)

ELECTRON SPIN RESONANCE (ESR) STUDIES OF RETURNED COMET NUCLEUS SAMPLES; Fun-Dow Tsay, Soon Sam Kim, and Ranty H. Liang, Jet Propulsion Laboratory, California Institute of Technology, Pasadena, CA 91109

INTRODUCTION. The most important scientific objective of the planned Comet Nucleus Sample Return Mission is to return to Earth the least altered, pristine samples which could reflect formation conditions and evolutionary processes in the early solar nebula. It is expected that the returned cometary samples will consist of fine-grained silicate materials mixed to some extent with ices composed of simple molecules such as H_2O , NH_3 , CH_4 as well as organics and/or more complex compounds. Because of the exposure to ionizing radiation from cosmic-ray, gamma-ray and solar wind proton at low temperature, free radicals in the form of $\bullet H$, $\bullet OH$, $\bullet CH_3$ and $\bullet CH_2$ are expected to be formed and trapped in the solid ice matrices. The kind of trapped radical species together with their concentration and thermal stability can be used as a dosimeter as well as a geothermometer to determine thermal and radiation histories as well as outgassing and other possible alternation effects since the nucleus material was formed. Since free radicals that are known to contain unpaired electrons are all paramagnetic in nature, they can be readily detected and characterized in their native form by the Electron Spin Resonance (ESR) method. In fact, ESR has been shown to be a non-destructive, highly sensitive tool for the detection and characterization of paramagnetic (Fe^{3+} , Ti^{3+} and Mn^{2+}), ferromagnetic (magnetite, hematite and metallic iron), and radiation damage centers in terrestrial and extraterrestrial geological samples (1-6). The purpose of this abstract is to point out the potential use of ESR as an effective method in the study of returned comet nucleus samples, in particular, in the analysis of fine-grained, solid state icy samples.

ESR SPECTROSCOPY. ESR measures the absorption of microwaves by a paramagnetic or ferromagnetic center in the presence of an applied external magnetic field. Conventional ESR experiments are carried out with varying magnetic fields on samples in a tuned resonant cavity operated at a certain frequency. The magnetic field position (g-value) at which resonance occurs, together with the number of resonance lines (fine and hyperfine structure) and the separation between them (zero-field splitting and hyperfine coupling constant), provides a direct identification of magnetic species, their oxidation state and chemical environment. Detailed analyses of ESR signals and their response to physical and chemical treatments can furnish further information on the nature, origin, thermal stability and formation condition of the magnetic species examined. The sensitivity of ESR is such that it can detect 3×10^{12} standard spin (or molecules assuming one spin per molecule). Thus, milligram-size cometary samples can be examined non-destructively as a function of temperature by ESR. In many instances, ESR has the advantage of detailed submicroscopic identification of transient species and/or reaction intermediates generated in UV and/or gamma-ray radiation. We intend to use the unique capability of ESR to investigate the thermal cycling, radiation exposure, shock effects and oxidation/reduction conditions in the formation and evolution of comet nucleus samples.

THERMAL AND RADIATION HISTORIES. Free radicals in the form of $\bullet OH$ and H_2O_2 have been detected in γ -irradiated ice at $77^\circ K$ (see Fig. 1). These free radicals are found to be unstable and to decay rapidly above $110^\circ K$ as reported (7). No ESR signals of the free radicals can be detected above $160^\circ K$. The characteristic ESR signals of $\bullet H$ having a hyperfine coupling

constant of 500 gauss and present in γ -irradiated ice can only be detected below 60°K (7). ESR studies have also been carried out on γ -irradiated formaldehyde (CH_2O) and UV-irradiated frozen aqueous solutions of glycine ($\text{NH}_2\text{CH}_2\text{COOH}$) at 77°K (see Fig. 1). The thermal and radiation histories as well as the extent of alternation for the returned comet nucleus samples can be determined from the time-temperature-dosage dependence of the ESR signals arising from various free radicals as produced by radiation and trapped in the cometary ice matrices.

SHOCK EFFECTS. The ESR methodology has been developed to determine shock-induced effects on carbonate minerals (5). By studying the ESR spectrum of Mn^{2+} present as impurity in calcite, it is possible to establish the distortion in the crystal structure as a function of shock loading and determine the shock loading history of a sample of unknown history. The lattice distortion caused by shock-induced effects can be effectively quantified through the ESR measurements of zero-field splitting parameters in Mn^{2+} . The characteristic ESR signals of Mn^{2+} in calcite have been detected in C-2 carbonaceous chondrites.

REDOX CONDITIONS. Previous ESR studies have successfully related the annealing temperature and surface exposure parameter to the magnetic properties of very fine lunar metallic Fe phases ubiquitously present (1-3). In addition, no ESR signals attributable to Fe^{3+} have been detected in the returned lunar surface samples, indicating highly reducing conditions prevail on the surface of moon. Recently, ESR has been used to make the first direct measurement of Ti^{3+} in meteoritic and synthetic hibonite (6). The ESR study has further established the use of $\text{Ti}^{3+}/\text{Ti}^{4+}$ ratios as indicators of oxygen fugacity in probing redox conditions in the early solar nebula (6). The ESR detection of the presence or absence of Fe^{3+} , Ti^{3+} and metallic Fe in the returned cometary samples should provide information about the formation conditions of comets and their subsequent evolutionary processes.

REFERENCES: 1. F. D. Tsay, S. I. Chan and S. L. Manatt, *Geochim. Cosmochim. Acta*, **35**, 865 (1971). 2. F. D. Tsay, S.I. Chan and S. L. Manatt, *Nature*, **237**, 77 (1972). 3. F. D. Tsay, S. L. Manatt and S. I. Chan, *Geochim. Cosmochim. Acta*, **37**, 1201 (1973). 4. T. J. Ahrens, F. D. Tsay and D. H. Live, *Proc. Seventh Lunar Sci. Conf.*, 1143 (1976). 5. J. Vizgirda, T. J. Ahrens and F. D. Tsay, *Geochim. Cosmochim. Acta*, **44**, 1059 (1980). 6. J. R. Beckett, D. Live, F. D. Tsay, L. Grossman and E. Stolper, *Geochim. Cosmochim. Acta*, **52**, 1479 (1988). 7. S. Siegel, J. M. Flournoy and L. H. Baum, *J. Chem. Phys.*, **34**, 1782 (1961).

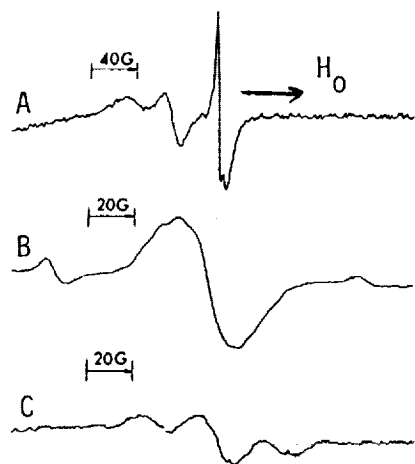

Fig. 1. A. The ESR spectrum observed for the γ -irradiated ice at 77°K. The center and high-field peaks are the doublet of $\cdot\text{OH}$, whereas the broad, low-field peak is due to HO_2 ; the sharp component which is superimposed on the high-field peak of the $\cdot\text{OH}$ doublet is due to the free electron trapped in ice. B. The ESR spectrum of γ -irradiated formaldehyde at 77°K. The low- and high-field peaks are the doublet of $\cdot\text{CHO}$, whereas the broadened center peak is the composite spectrum of the ESR signals arising from multiple radical species ($\cdot\text{CH}_3$, $-\text{OCHO}-$ and $\cdot\text{OCHO}$); the ESR signals disappear above 210°K. C. The triplet ESR spectrum observed for $-\text{CH}_2$ radicals in the UV-irradiated ice containing 0.2 M glycine at 77°K. The ESR signals decay rapidly at high temperature.

ION BOMBARDMENT EXPERIMENTS SUGGESTING AN ORIGIN FOR ORGANIC PARTICLES IN PRE-COMETARY AND COMETARY ICES

Thomas J. Wdowiak, Edward L. Robinson, Gregory C. Flickinger, and David A. Boyd, Physics Department, University of Alabama at Birmingham, Birmingham Al 35294

During the Giotto and Vega encounters with Comet Halley both organic particles called CHON (1,2), and energetic ions (3,4) were detected. The acceleration of ions to hundreds of keV in the vicinity of the bow shock and near the nucleus may be a demonstration of a situation occurring in the early solar system (perhaps during the T Tauri stage) that led to the formation of organic particles only now released. Utilizing a Van de Graaff accelerator and a target chamber having cryogenic and mass spectrometer capabilities (5), we have bombarded frozen gases at 10 K with 175 keV protons with the result that fluffy solid material remains after sublimation of the ice (6,7). Initial experiments were carried out with a gas mixture in parts of 170 carbon monoxide, 170 argon, 25 water, 20 nitrogen, and 15 methane formulated to reflect an interstellar composition in experiments involving the freezing out of the products of a plasma (8). The plasma experiments resulted in a varnish-like film residue that exhibited luminescence when excited with ultraviolet radiation, while the ion bombardment created particulate material that was not luminescent.

We have varied the composition of the gas mixture frozen out at 10 K including using carbon dioxide instead of carbon monoxide, and have determined the formation of particulate residues rather than films is more a characteristic of the ion bombardment process than a characteristic of specific ice composition. Quadrupole mass spectroscopy during 175 keV proton bombardment (as molecular hydrogen ions accelerated with a potential of 350 keV) of carbon monoxide, argon, and water ice indicates formation of species at m/q peaks 29, 30, 32, and 44 suggestive of formyl radical, formaldehyde, methanol, and carbon dioxide (Fig. 1). The infrared spectrum of a fluffy residue prepared from (in parts) 170 carbon monoxide, 25 water, 20 nitrogen, and 15 methane is shown with that of material evaporated from the Orgueil acid insoluble residue during rapid heating in vacuum to 500 C (Fig. 2). The fluffy residue can be imaged by SEM with 1.1 keV electrons without application of a conductive coating, indicating it may not be necessary to coat samples while using a spacecraft SEM avoiding an obvious complication (6).

The formation of particulate material that can be easily broken into fragments is of interest as a laboratory analogue for CHON (1,2). During the T Tauri stage of the sun when the solar wind mass flow could have been 7 to 8 orders of magnitude of its present value, considerable shock activity would have been present with ions accelerated in the shock environment as found for Comet Halley (3,4), the earth's bow shock, and interplanetary shocks. Ice grains and "chunks" (up to several centimeters in size) bombarded by these moderate energy ions (100 keV) would then have particulates formed

within. Aggregation of the bombarded ice grains and "chunks" into a cometary nucleus results in particulates being distributed throughout. Subsequent bombardment of the nucleus surface by shock accelerated ions would yield an enhanced surface layer of dust. The process could also take place at the surface of icy satellites. T. J. Wdowiak acknowledges NASA grant NAGW-749.

References: (1) Kissel, J. et al. (1986) *Nature*, V. 321, 280; (2) Kissel, J. et al. (1986) *Nature*, V. 321, 336; (3) Somogyi, A. J., et al. (1986) *Nature*, V. 321, 285; (4) McKenna-Lawlor, S. et al. (1986) *Nature*, V. 321, 347; (5) Wdowiak, T. J. et al. (1985) *Nucl. Instr. and Meth.*, B10/11, 735; (6) Wdowiak, T. J. et al. (1988) *Lunar and Planetary Sci.* 19, 1249; (7) Wdowiak, T. J. et al. (1988) in *Experiments on Cosmic Dust Analogues* (E. Bussoletti et al. eds, Kluwer) 271; (8) Wdowiak, T. J. et al. (1989) *Ap. J.* (in press, January 15).

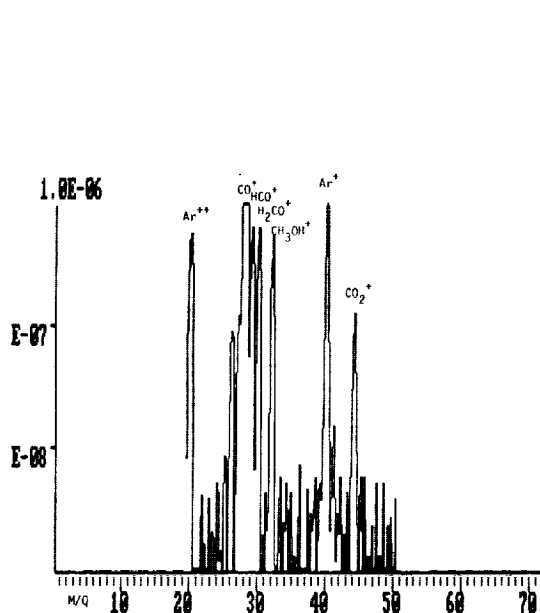

Fig 1. Mass spectrum of species ejected from a CO, Ar, and water ice during ion bombardment.

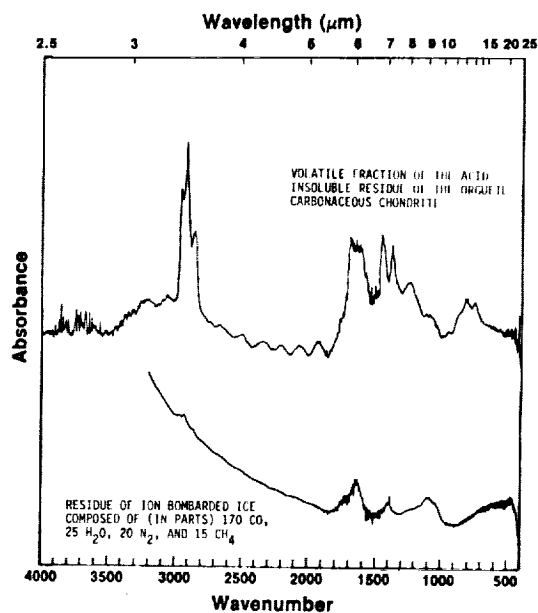

Fig 2. Infrared spectra of residue of ion bombarded ice and volatile fraction of the acid insoluble residue of the Orgueil meteorite.

PHYSICAL PROCESSING OF COMETARY NUCLEI; Paul R. Weissman, Jet Propulsion Laboratory, and S. Alan Stern, University of Colorado.

Cometary nuclei were formed far from the Sun in the colder regions of the solar nebula, and have been stored in distant orbits in the Oort cloud over most of the history of the solar system. It had been thought that this benign environment would preserve comets in close to their original pristine state. However, as discussed below, recent studies have identified a number of physical processes that have likely acted to modify cometary nuclei in a variety of significant ways.

Accretion of interstellar material has long been considered as a means of providing comets with a volatile "frosting" that could explain the anomalous brightness of dynamically "new" comets on their first passage through the planetary system (Whipple, 1978). However, the likely erosion rate of cometary surfaces by hyper-velocity impacts of interstellar dust particles exceeds the accretion rate by a factor of 500 to 700 (Stern, 1986). On the other hand, impacts of grains into the fluffy aggregates suspected for cometary nuclei may allow capture with minimal erosion (Ostro et al., 1986).

Collisions of nuclei with cometary debris can have significant effects on cometary regoliths (Stern, 1988), particularly in the inner Oort cloud where they are likely frequent enough to promote global surface development to a depth of meters, and highly localized turnover to 10 to 50 meters.

Heating by short-lived radionuclides is not expected to be relevant to comets because of their long accretion times in the distant regions of the solar nebula and because of their small size. Longer lived heat sources could be significant but only for very large cometary nuclei, > 30 km radius, or for very low values of the thermal conductivity (Lewis, 1971).

Comets in the distant Oort cloud receive little solar heating but are sporadically warmed by nearby supernovae. Stern and Shull (1988) estimate that all cometary surfaces have been heated at least once to 50 K, with a 50% probability that the heating has been > 60 K. Random passing stars also heat comets and simultaneously eject them from the Oort cloud; the effective ejection radius is larger than the effective heating radius for all but the most luminous OB stars and associations, so the net heating effect is much less than for supernovae.

Irradiation of cometary nuclei by galactic cosmic rays during storage in the Oort cloud provides an energy source for chemical reactions in the upper several meters of the nucleus surface, resulting in sputtering of volatiles, creation of free radicals, and polymerization of hydrocarbons (Johnson et al., 1987). Thus, the comet develops a nonvolatile crust on its surface prior to ever entering the planetary region. This crust may be blown off (all or in part) when the comet approaches the Sun, or may form the basis for further crust growth as the nucleus warms and more volatiles sublime away.

When comets are perturbed into the planetary system, they undergo a slow warming from the increasing levels of solar insolation. Typical internal temperatures for any given orbit are given by the fast rotation average:

$$T_i = 280 (1 - A)^{1/4} a^{-1/2} e^{-1/4} \text{ K}$$

where A is the surface albedo, a is the orbital semimajor axis, and e is the emissivity, plus or minus 10% depending on the orbital eccentricity and on the thermal properties of the surface materials (Herman and Weissman, 1987). However, it may take very many orbits for the nucleus interior to warm to some equilibrium temperature, during which planetary perturbations may change the orbit repeatedly. Thus, the internal temperature profile of the nucleus will be a complex function of its orbital history.

If comets did indeed form in the colder regions of the solar nebula, then they likely formed as amorphous ices. As the nucleus is heated the amorphous ice undergoes an exothermic phase transition to crystalline ice at about 120 - 140 K. Prialnik and Bar-Nun (1987) find that a new comet undergoes this transition at about 5 AU inbound to the Sun, and a layer about 15 meters thick on the nucleus surface is transformed. On subsequent orbits the transformation does not re-occur until the crystalline layer sublimates away to some minimum thickness that allows solar energy to be conducted to the amorphous layers below. The transition then repeats, but penetrates deeper on each successive transition as the nucleus interior gradually warms. Eventually the entire comet is transformed into crystalline ice.

Continued heating results in loss of volatiles from the nucleus, further contributing to the generation of a non-volatile lag deposit on the surface. Various studies (Brin and Mendis, 1979; Fanale and Salvail, 1984; Horanyi et al., 1984) have attempted to quantify this process but with less than total success. In particular, the question of why crusts form at some sites on the nucleus and not at others, is not understood. Also, it is not known whether active areas manage to perpetuate themselves or whether they sporadically appear, persist for some fraction of an orbit (or orbits), and then die out to be replaced by other sporadic events.

Another poorly understood area is thermo-mechanical stresses on cometary nuclei. The sharp thermal gradients resulting from the expected low thermal conductivity of cometary materials should provide a means for mechanical breakup of crusts, and possibly even the nucleus itself. However, studies to date (Kuhrt, 1984; Green, 1986) have not yet even agreed if the stresses are tensional or compressional, and the poor knowledge of the precise nature of cometary materials makes more exact calculations extremely difficult.

It is important to consider all of these possible processes, both in deciding on a site on the nucleus for collection of cometary samples, and in interpreting the results of analyses of returned cometary samples. Although it can no longer be said that comets are pristine samples of original solar nebula material, they are still the best obtainable samples of that unique period in the formation of the planetary system.

References: Brin, G.D. & Mendis, D.A. 1979, *Astrophys. J.* 229, 402; Fanale, F.P. & Salvail, J.R. 1984, *Icarus* 60, 476. Green, J.R. 1986, *B.A.A.S.* 18, 800 (abstract). Herman, G. & Weissman, P.R. 1987, *Icarus* 69, 314. Horanyi, M., et al. 1984, *Astrophys. J.* 278, 449. Johnson, R.E., et al. 1987, *Astron. Astrophys.* 187, 889. Kuhrt, E. 1984, *Icarus* 60, 512. Lewis, J.S. 1971, *Icarus* 15, 174. Ostro, S.J., et al. 1986, *Amer. Meteor. Soc.* (abstract). Prialnik, D. & Bar-Nun, A. 1987, *Astrophys. J.* 313, 893. Stern, S.A. & Shull, J.M. 1988, *Nature* 332, 407. Stern, A. 1986, *Icarus* 68, 276. Stern, S.A. 1988, *Icarus* 73, 499. Whipple, F.L. 1978, *Moon & Planets* 18, 343.

CONTRIBUTION TO PANEL DISCUSSION ON THE MATERIAL RETURNED FROM A COMET; E. Whalley, Division of Chemistry, National Research Council of Canada, Ottawa K1A 0R6 CANADA.

As comets are only a few kilometres in diameter, probably none of the high-pressure phases of ice will normally be formed in them. Their principal constituents are likely to be ice I, either cubic or hexagonal, clathrate hydrates of methane, ethane, etc., ammonia hydrates, and other similar compounds of solid solutions. Amorphous forms are probably the more common.

When samples of a comet are returned to earth, they can be studied in numerous ways. If the sample is metastable near liquid-nitrogen temperature, a wide range of measurements can be made, such as x-ray and neutron diffraction, infrared and Raman spectroscopy, neutron inelastic scattering, nuclear magnetic and electron-spin resonance spectroscopy, etc. X-ray diffraction by samples of ice that were recovered at liquid-air temperature, i.e. 87K, were made by McFarlan in 1936, and many have followed him, usually using liquid nitrogen.

In our laboratory, we have studied many crystalline and amorphous phases of ice that have been recovered at low pressure and 77 K, including most of those mentioned in the preceding paragraph, starting in 1963. Many of these techniques can be used for studying recovered samples of the ices that occur on comets.

References: Bertie, J. E., Calvert, L. D. and Whalley, E. J. Chem. Phys. 38, 840-846 (1963).

REFRACTORY SOLIDS IN CHONDRITES AND COMETS: HOW SIMILAR?

John A. Wood, Harv.-Smiths. Center for Astrophysics, Cambridge MA 02138, USA.

The grains of ice, dust, and organic material that came together to form the solar system have been preserved to differing degrees in the most primitive solar system bodies, asteroids and comets. The study of samples of asteroids (in the form of chondritic meteorites) reveals that the dust component was extensively altered by high-temperature events and processes in the early solar system, before it was aggregated into chondritic planetesimals. The nature of these high-temperature events and processes is not known, but the evidence of their operation is pervasive and unequivocal. Reviewing properties of the three principal types of particulate matter in chondrites:

CA, AL-RICH INCLUSIONS (CAI's) are depleted in relatively volatile elements. High-temperature events either incompletely vaporized precursor material; or totally vaporized it, after which the system cooled and recondensed selectively, such that the CAI's incorporated only early high-temperature condensates. Isotopic mass-fractionation effects measured in Mg, Si, Ca, and Ti in CAI's indicate that the latter experienced a complex history of both partial vaporization and condensation. On the other hand, the fact that some CAI's contain O, Mg, Si, Ca, Sr, Ba, Nd, and Sm with anomalous isotopic compositions that are not attributable to mass fractionation or radioactive decay, but must be the signatures of particular nucleosynthetic sources, indicates that these objects contain a component that was never vaporized and mixed with other solar system material. Many CAI's display mineralogical and textural evidence of having been melted.

Similar evidence shows that virtually all CHONDRULES were largely or wholly melted. Many chondrules contain relic grains of mineral matter that survived the chondrule-melting event, and which represent an earlier state of solar system solids. Whether these are condensate grains, fragments from an earlier generation of igneous chondrules, or (conceivably) presolar grains is not known. Generalizing from limited data, chondrules show the same kinds of isotopic mass fractionation effects and presolar isotopic anomalies as CAI's, but the extent of the effects (ranges of del values found) is more modest.

MATRIX in chondrites consists of aggregated mineral grains, mostly in the 1-10 micron size range. Where the grains are not obviously secondary (postaccretional) alteration products, they have been variously interpreted to be nebular condensates or comminuted debris from the collisions of larger objects. The only known bona fide presolar interstellar grains in chondrites occur in the matrix. These are submicron grains of carbonaceous matter: organic carbon, diamond, graphitic or amorphous carbon, and SiC. Each exhibits a different anomalous isotopic signature (for C, included noble gases, and Si, where present), presumably impressed upon it by a different nucleosynthetic site. The matrix may also contain a minor component of other interstellar phases, such as silicates, but these have not been identified.

Are the refractory particles in comets likely to be similar to these chondrite components? Probably not (except for the presolar carbonaceous grains in chondrites), because the chondritic components are products of severe thermal processing, and all imaginable energy sources that could have provided the heat tend to diminish with distance from the sun. Every indication is that comets formed at much greater radial distances than asteroids,

so the particles they incorporated would have experienced less heating. The possibilities cannot be completely ruled out that comets, too, formed inside the present orbit of Jupiter (this was part of Oort's [1950] original concept), or that thermally-processed grains were able to diffuse great radial distances before being incorporated in accreting objects, but it is far more likely that most of the refractory grains in comets have been spared the extreme thermal processing that shaped the character of chondritic components. Perhaps some of the grains are presolar material that has experienced only a minor degree of nebular processing. The study of grains in the first stage of conversion to CAI's and chondrules could help us understand what was accomplished much more thoroughly in the inner solar system.

Almost certainly a major proportion of the refractory solids in comet nuclei consist of essentially pristine presolar interstellar grains. Spectral studies of interstellar and circumstellar grains provide only an approximate picture of their nature. The grains are small, the order of 0.1 micron, but it is unclear whether the size distribution also includes populations of much smaller and much larger grains. Magnesian silicate and carbonaceous grains are present. The silicates may be amorphous or crystalline, or anything between. The spectral information comes only from the Mg-silicates, which are most abundant; there is no information on the interstellar carriers of Ca, Al, and the less abundant condensable elements, and even the major carriers of Fe are conjectural. The carbonaceous component consists of SiC, elemental C in one or more forms (amorphous C, graphite, turbostratic graphite, diamond), and, probably, complex organic compounds.

At this point we have had two glimpses of the nature of cometary refractory particles: as interplanetary dust particles (IDP's) collected in the stratosphere, and from analyses by the instruments of Giotto and Vega during the 1986 encounter of Halley's comet.

It is likely, though not certain, that a subset of IDP's (the chondritic porous aggregates) consists of cometary particles. These are aggregates of 0.1-1 micron crystals of mafic and other minerals, coated and cemented together by carbonaceous material. Highly anomalous D/H ratios have been found associated with the carbonaceous material, presumably resulting from mass fractionation in the very cold presolar dense interstellar medium. However, most ion microprobe analyses of (clusters of) embedded silicate grains have not revealed isotopic anomalies.

Halley particles collected and analyzed by the Vega 1 impact mass spectrometer were mostly in the 0.1-1 micron size range. The particles were highly variable in composition, but typically consisted of mineral cores of more or less chondritic composition surrounded by carbonaceous mantles.

The question of whether involatile particles collected by a comet nucleus sample return mission are nebular condensates or presolar interstellar grains is most likely to be settled by isotopic analysis, using improved ion microprobe mass spectrometers. The latter will have sensitivities and spatial resolutions that permit analysis of individual 0.1-1 micron cometary grains. They will detect the differing isotopic signatures of condensates derived from multiple nucleosynthetic sources, if the grains are presolar. If the grains condensed from the nebula, on the other hand, these signatures cannot have survived, and this will be readily apparent.

ISOTOPIC MICROANALYSIS OF RETURNED COMET NUCLEUS SAMPLES. Ernst Zinner, McDonnell Center for the Space Sciences and Department of Physics, Washington University, St. Louis, MO 63130 USA.

If isotopic measurements of interplanetary dust particles (IDPs) and primitive meteorites can serve as a guide to the isotopic analysis of returned comet nucleus material, an essential requirement will be the capability for microanalysis. The reason is that in both types of extraterrestrial samples large isotopic heterogeneities on a small spatial scale have become apparent once it was possible to measure isotopes in small samples. In the discovery of large isotopic anomalies the ion microprobe has played a significant role because of its high spatial resolution for isotopic ratio measurements. The largest isotopic anomalies in C, N, O, Mg, Si, Ca and Ti found to date were measured by ion microprobe mass spectrometry [1]. The most striking examples are D/H measurements in IDPs [2,3] and isotopic measurements of C, N and Si in SiC from the CM chondrites Murray and Murchison [4,5].

A number of IDPs shows large D excesses that are heterogeneous on a size scale of several μm . In one particular example, in the IDP Butterfly, a large D excess ($\delta\text{D} \geq 10000\text{‰}$) was found to be concentrated in a region smaller than $1 \mu\text{m}$ [3]. In contrast to IDPs, unequilibrated ordinary chondrites that have large D excesses in bulk material do not show significant heterogeneities of the D/H ratio on a μm scale and to date no D rich hot spots have been found [6]. This might reflect the difference between more processed meteoritic and more pristine cometary material. Although it presently cannot be proven for any given IDP, many IDPs undoubtedly are of cometary origin. It has been argued that D enrichments in IDPs and meteorites are of interstellar cloud origin [cf. 7]. It is thus not unlikely that comets contain presolar material. Many links in this chain of reasoning are uncertain, it is certain, however, that the capability of isotopic microanalysis will be necessary to decide these questions.

Meteoritic SiC shows extreme isotopic anomalies in C, N, Si, Ne and Xe [4,5], with large isotopic heterogeneities for the first three elements in individual grains of a few μm in size [8]. Arguments for a presolar, circumstellar, origin of SiC grains are based on their isotopically anomalous composition and the fact that the chemical conditions (C/O < ratios) in the early solar system would not have allowed their formation. SiC has also been reported in IDPs [9]. No isotopic data have been obtained on these samples, but the ^{13}C excess measured in a fragment of the IDP could be due to the presence of SiC [9]. Again, based on the presence of SiC in meteorites and IDPs, it can be expected that such presolar grains will be found in comet nucleus samples. While the list of isotopic measurements in small extraterrestrial samples could be extended (cf. noble gases, O and Mg in IDPs) one should consider possible future developments that will bear on the isotopic analysis of returned comet nucleus material.

1. Extension of isotopic measurements in IDPs to other elements. Candidates are N but also Ca and Ti in refractory particles whose O isotopic compositions are proof of their extraterrestrial origin [10].
2. Development of methods to perform *in situ* isotopic measurements of volatile elements in ices. Isotopic information is expected to be not only contained in cometary mineralic matter but also in ices. While isotopic measurements of gases released by evaporation of ices will certainly play a role, it may be even more important to make *in situ* measurements. Slicing of ices for TEM studies is already within present technical

E. Zinner

capabilities.

3. Better spatial resolution. Laser ablation of volatile coatings in a method that could achieve high depth resolution. High lateral resolution (*in situ* analysis of small grains) will probably be tied to sputtering by finely focussed ion beams (ion microprobe). A resolution of a few hundred Å can presently be achieved [12].
4. Increase in sensitivity. The number of atoms of a given species in a sample sets the ultimate limit for isotopic analysis, but in present mass spectrometers only a small fraction of these atoms are actually detected. Laser resonance ionization promises to selectively ionize nearly all atoms of a given element. The next step would be ion-resonant ionization of all elements in the sample and simultaneous detection of all their isotopes. Such developments will have to depend on advances in laser technology (UV lasers) and novel mass spectrometer concepts (e.g. Fourier transform mass spectrometry).
5. Exploration of non-destructive methods for isotopic analysis. There is a whole series of spectroscopic techniques (NMR, Raman) that, in principle, allow non-destructive isotopic measurements. Whether any of them are sensitive enough to become attractive for the analysis of microsamples remains to be seen.

References:

- [1] Zinner E. (1988) USGS Bulletin, in press.
- [2] McKeegan K. D. *et al.* (1985) *Geochim. Cosmochim. Acta* **49**, 1971-1987.
- [3] McKeegan K. D. *et al.* (1987) *Lunar Planet. Sci.* XVIII, 627-628.
- [4] Zinner E. *et al.* (1987) *Nature* **330**, 730-732.
- [5] Tang M. *et al.* (1988) *Lunar Planet. Sci.* XIX, 1177-1178.
- [6] Walker R. M. and Zinner E. (1988) *Meteoritics* **23**, in press.
- [7] Zinner E. (1988) In *Meteorites and the Early Solar System* (J. Kerridge, ed.), Chapter 13.2, Univ. Arizona Press, p.956-983.
- [8] Zinner E. *et al.* (1988) in preparation.
- [9] Bradley J. and Brownlee D. E. (1983) *Lunar Planet. Sci.* XIV, 67-68.
- [10] McKeegan K. D. (1987) *Science* **237**, 1468-1471.
- [11] Levi-Setti R. *et al.* (1985) *Scanning Electron Microscopy/1985 II*, 535-551.

THE MEASUREMENT OF TRACE ELEMENTS IN INTERPLANETARY DUST AND COMETARY PARTICLES BY ULTRA-HIGH SENSITIVITY INAA

M.E. Zolensky¹, D.J. Lindstrom², R.M. Lindstrom³ and M.M. Lindstrom¹;
¹Planetary Science Branch, NASA/Johnson Space Center, Houston, TX;
²Lockheed Engineering and Science Co., Houston, TX; ³National Institute of Standards and Technology, Gaithersburg, MD.

INTRODUCTION Today the major element composition of interplanetary dust particles (IDPs) is routinely determined in many laboratories. These and mineralogical studies have revealed the presence of at least two major types of IDPs, chondritic and refractory. Chemical and mineralogical data bases for IDPs have expanded to the point where workers are beginning to suggest possible parent bodies for some samples, and outline possible thermal-pressure-chemical histories as well [1-3]. This work generally involves analogies to meteorites. However, these comparisons remain at a primitive state partly due to the lack of trace element information from IDPs. Trace element analysis is geochemically important, with the potential for revealing details of condensation/crystallization processes, metamorphism, aqueous alteration, melting and partial evaporation. Most of these processes played important roles in the histories of IDPs, as well as comets from which many IDPs are certainly derived. There have been previous efforts to collect trace element data from IDPs, which have been successful for limited numbers of trace elements using INAA (Na, Sc, Cr, Fe, Co, Ni, Zn, Au[?] and Ir[?]), PIXE (S, K, Ca, Fe, Ni, Zn, Ge, Se and Br) and Synchrotron XRF (Cr, Mn, Fe, Ni, Cu, Zn, Ga, Ge, Se and Br) [4-6]. We report here preliminary results of a successful attempt to determine abundances of a large suite of trace elements from both chondritic and refractory IDPs. We then describe how our analytical procedure can be used in the grain-by-grain analysis of returned cometary samples.

EXPERIMENTAL PROCEDURE Chondritic and refractory IDPs are characterized by standard SEM-EDX techniques. In general, samples are not coated for these analyses in order to permit later analysis of intrinsic noble metals and carbon. IDPs analyzed to date have ranged in size from about 15-50 μm in greatest diameter. These particles are sealed individually into high-purity silica tubes and irradiated for approximately 1 week in the highest possible neutron flux ($3.0 \times 10^{14} \text{ cm}^{-2} \text{ sec}^{-1}$) in the reactor at the National Institute of Standards and Technology. The particles are then released from incarceration in the tubes, and are deposited between two fresh dimpled plastic slides. Gamma-ray spectrometry is performed using a large (55% efficiency) Ge detector in the ultra-low level Radiation Counting Laboratory at the NASA Johnson Space Center. This unique laboratory was specially designed and constructed to minimize natural background radiation. With our system, detection limits for many elements are well below picogram levels, and some approach femtograms. This technique is non-destructive, although some sample handling is required, so particles can be analyzed by other techniques after INAA is completed.

RESULTS We are presently reducing data from the analyses of 7 IDPs. These are U2015E10, U2015F1, W7029*A2, W7029*A3, W7013A8, LAC1 (all chondritic) and 705 (refractory). We have, so far, detected and measured 17 different major and trace elements in these particles, including rare earths and some very volatile elements (Br and Zn). We will present the final data at the workshop.

DISCUSSION Even the preliminary data we present here are sufficient to demonstrate that we can routinely measure a large suite of trace elements within IDPs, and samples of similar dimensions. With time we expect to build up a large data base of trace element data of IDPs of all types, which will permit us to more accurately determine the origin and histories of these samples. As many of the chondritic IDPs probably originate from comets, this research will, in a larger sense, reveal the geochemical processes active on comets. Of more direct value to this workshop, however, is that we are now in an excellent position to apply this technique to samples returned from a comet nucleus. Assuming that comets are largely aggregates of relatively unprocessed dust grains and ices, it will be necessary to analyze cometary samples on a grain-by-grain basis. Our INAA technique will permit the measurement of trace elements in the dust fraction of such samples.

REFERENCES [1] Mackinnon I.D.R. and Rietmeijer F.J.M. (1987) Reviews of Geophysics 25, 1527-1553; [2] Schramm L.S. et al. (1988) Lunar and Planetary Science XIX, 1033-1034; [3] Zolensky M.E. et al. (1989) Proceedings of the Nineteenth Lunar and Planetary Science Conference, in press; [4] Ganapathy R. and Brownlee D.E. (1979) Science 206, 1075-1077; [5] van der Stap C.C.A.H. et al. (1986) Lunar and Planetary Science XVII, 1013-1014; [6] Sutton S.R. and Flynn G.J. (1988) Proceedings of the Eighteenth Lunar and Planetary Science Conference, 607-614.

